

Drive solutions for bucket elevator applications

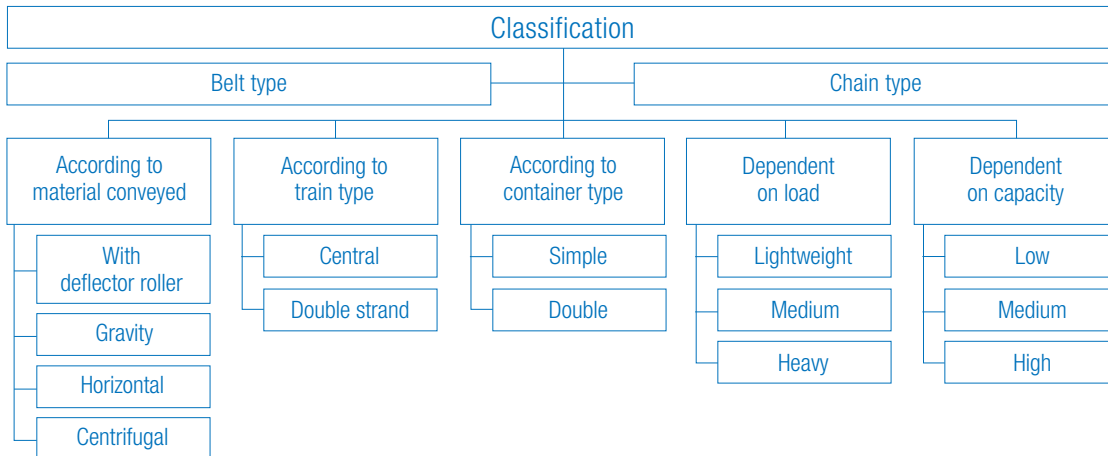

Versions

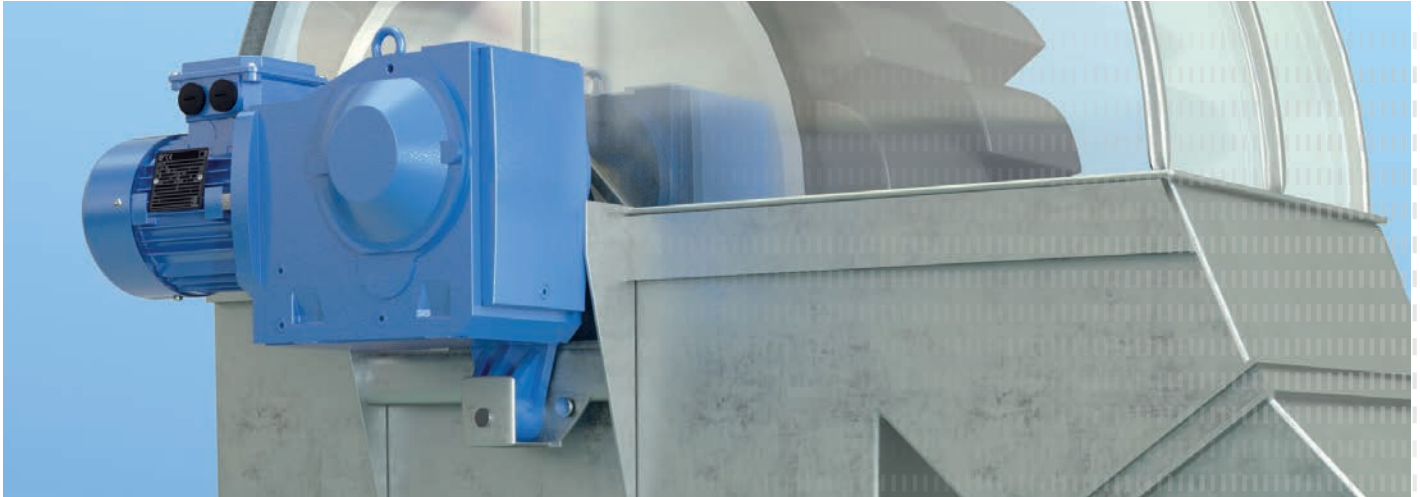
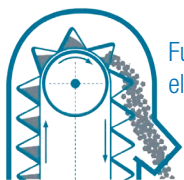

Full bucket elevator

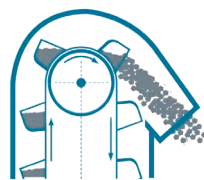

Centrifugal bucket elevator

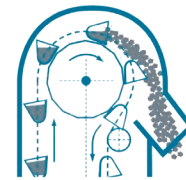

Bucket elevator with deflector roller

- ▶ Low speed
- ▶ Closely spaced containers
- ▶ Direct filling of material into the containers via conveyor ramp
- ▶ Tipping of material from the inverted containers into the discharge shaft

- ▶ High speed
- ▶ Material shovelled out at the bottom of the system
- ▶ Discharge by centrifugal force
- ▶ For fine grain size

- ▶ Low speed
- ▶ For light material which tends to stick in the containers
- ▶ The load is picked up at the bottom similarly to centrifugal bucket elevators
- ▶ Discharge by inverting the buckets at low speed

Drive solutions for bucket elevator applications

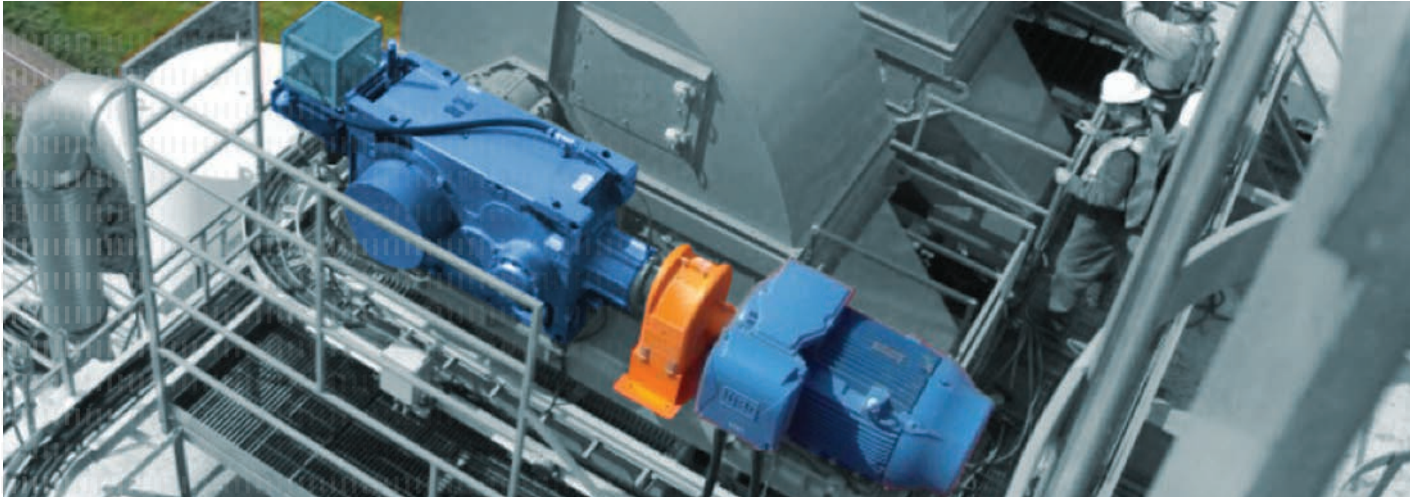

Typical features of low capacity bucket elevators

UNICASE™ bevel gear units (Catalog G1000)



- ✓ Foot, flange, or hollow shaft mounted
- ✓ Hollow or solid shaft
- ✓ Long life, low maintenance
- ✓ UNICASE housing

Sizes: 11
 Power: 0.16 - 268 HP
 Torque: 1,593 - 442,537 lb-in
 Ratio: 8.04 - 13,432.68:1

UNICASE™ parallel shaft gear units (Catalog G1000)



- ✓ Foot, flange, or hollow shaft mounted
- ✓ Hollow or solid shaft
- ✓ Compact design
- ✓ UNICASE housing

Sizes: 15
 Power: 0.16 - 268 HP
 Torque: 974 - 885,075 lb-in
 Ratio: 4.03 - 15,685.03:1

Gear unit options recommended by NORD DRIVESYSTEMS

Name	Meaning
A	Hollow shaft
AZ	Hollow shaft, B14 flange
AZD	Hollow shaft, B14 flange, with torque arm
AZK	Hollow shaft, B14 flange, with torque console
BH	Fastening element for hollow shaft with cover as a touch guard
G	Rubber buffer for torque arm (parallel shaft gear unit)
SH	Hollow shaft with shrink disc and cover as a touch guard

Motor options recommended by NORD DRIVESYSTEMS

RLS	Back stop
IP66	Protection against entry of water and dust
PTC/KTY/ PT100	Temperature sensor

High-efficiency motors

ATEX	Explosion protected motors for explosion hazard areas
------	---

Explosion protected drive solutions



NORD DRIVESYSTEMS supplies customized explosion protected motors and geared motors.

- ▶ Versions and equipment according to individual requirements
- ▶ Configuration processes validated according to ISO 9001
- ▶ Safe, SAP-supported modular system

Dust explosion protected motors

- ▶ Category 2D or 3D, Zone 21 or 22
- ▶ According to EN 60079-31
- ▶ Ignition protection type Ex t (protected by housing)

Gas explosion protected gear units

- ▶ Category 2D or 3D, Zone 21 or 22
- ▶ According to EN 13463
- ▶ Ignition protection Type C (design safety)

Hazardous locations

- ▶ Class I, Division 2 Groups A, B, C, D
- ▶ Class II, Division 2 Groups F and G Temp Code T3B

Variable frequency drive controlled bucket elevators

Advantages

- ▶ Easy commissioning
- ▶ Variable speed
- ▶ Adjustable torque ramp
- ▶ Safety functions
- ▶ High efficiency
- ▶ Load-dependent speed control reduces wear
- ▶ Parameterization according to process requirements

NORDAC® FLEX SK 200E variable frequency drive (Catalog E3000)



- ✓ Energy-saving function
- ✓ Integrated POSICON positioning control
- ✓ Integrated PLC

Voltage: 1~ 110 – 120 V, 1~ 200 – 240 V
3~ 200 – 240 V, 3~ 380 – 500 V
Power: 0.33 - 30 HP

NORDAC® PRO SK 500E variable frequency drive (Catalog E3000)



- ✓ Stand-alone operation
- ✓ 4 parameter sets
- ✓ Sensorless current vector control (ISD control)
- ✓ Integrated PLC

Voltage: 1~ 110 – 120 V, 1~ 200 – 240 V
3~ 200 – 240 V, 3~ 380 – 480 V
Power: 0.33 - 200 HP

Drive solutions for bucket elevator applications

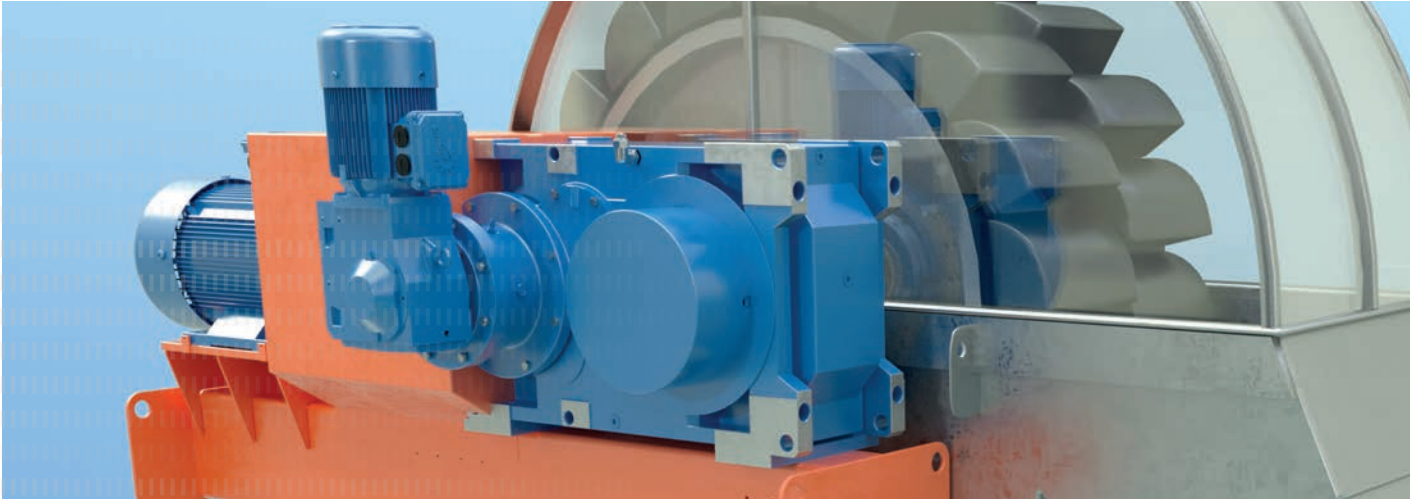

MAXXDRIVE® industrial gear units (Catalog: G1050)

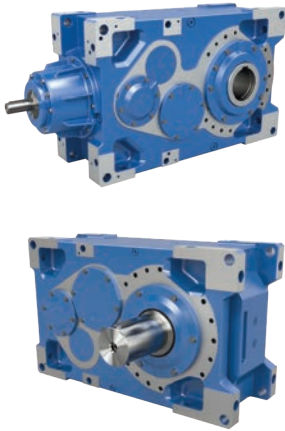

- ✓ Parallel axis and right-angled gear units
- ✓ High axial load capacity
- ✓ Long life, low-maintenance
- ✓ UNICASE™ housings
- ✓ Hollow or solid shaft
- ✓ Foot motor (IEC B3)
- ✓ Hydraulic clutch
- ✓ Back stop
- ✓ Brake
- ✓ All components can be mounted on a motor swing arm or a steel frame
- ✓ High efficiency IE3 motor
- ✓ ATEX motors for applications in explosive environments

Sizes: 11
 Power: 2.5 – 8,075 HP
 Torque: 132,800 – 2,495,900 lb-in
 Ratio: 5.54:1 – 30,000:1

Grain Endurance Package

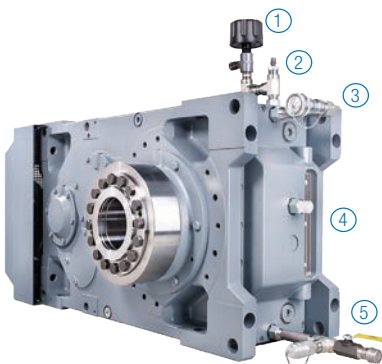

The Endurance Package from NORD DRIVESYSTEMS is a combination of several protective measures that ensure your investment will have a long operating life.

- 1 Drying agent filter
- 2 Oil sampling port
- 3 Quick fit filter trolley connection
- 4 Oil inspection glass
- 5 Quick fit filter trolley connection and oil drain cock

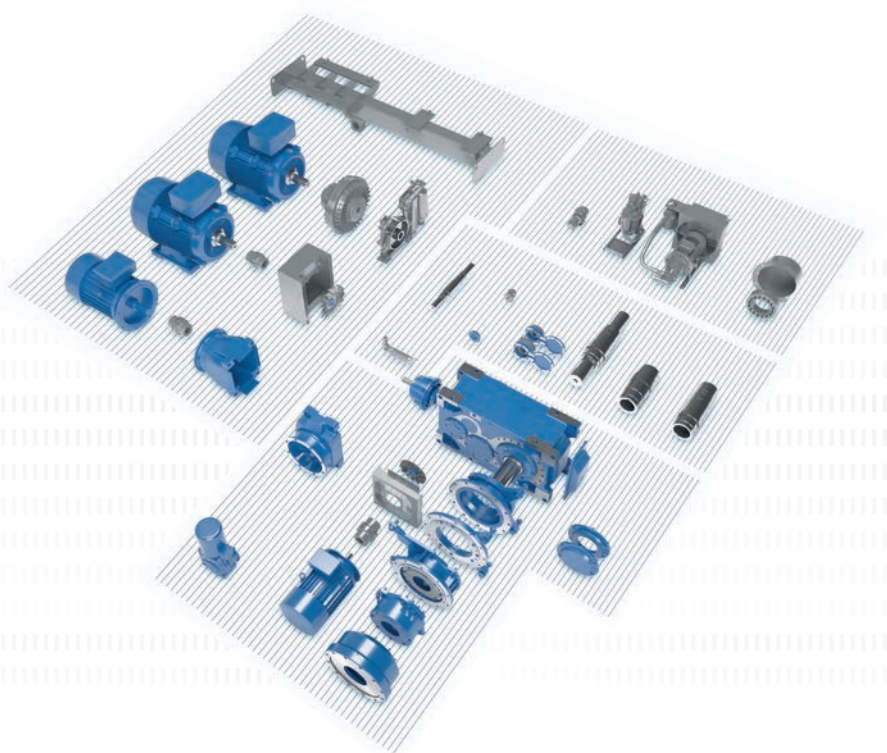

Recommended options for high capacity bucket elevators

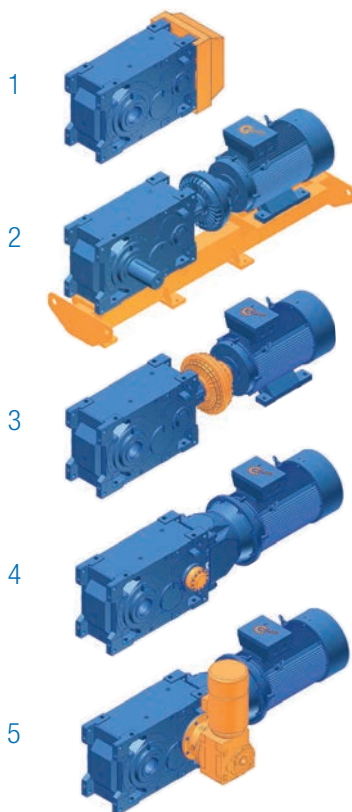

MAXXDRIVE® industrial gear units are based on the modular system from NORD DRIVESYSTEMS and provide many individual options such as:

1 Axial fans

The high performance axial fan is mounted directly on the drive shaft and provides high cooling power and a thermal reserve.

2 Base frame / motor rocker

All mechanical and electrical components are mounted on a motor rocker or a motor frame, which simplifies the installation of the drive train.

3 Fluid coupling

The fluid coupling enables the conveyor belt to start gently and prevents excessive tensile forces on the belt and high torques in the gear unit. It also reduces the starting current.

4 Back stop

The back stop prevents run-back with inclined conveyor belts. All back stops are externally mounted and can be replaced without having to dismantle the gear unit. They are also lubricated with the gear oil.

5 Auxiliary drive unit

Auxiliary Drive units include an overrunning clutch for when it becomes necessary to operate the system at slow speed or “inch” the main reducer.

6 Taconite seal

The Taconite seal prevents damage to the shaft sealing rings in abrasive or dusty environments. It consists of a labyrinth seal which can be re-lubricated to keep abrasive dust away from the seal.

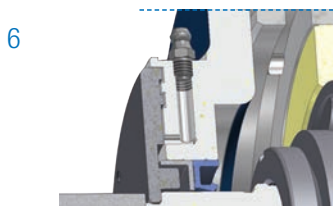

NORD DRIVESYSTEMS

Drive solutions for bucket elevator applications



NORD drive solutions are used worldwide in industries that rely on bucket elevators.

- ▶ Food industry
- ▶ Mining industry
- ▶ Cement and mineral industry
- ▶ Fertilizer industry
- ▶ Chemical industry

Complete drive solutions from a single source

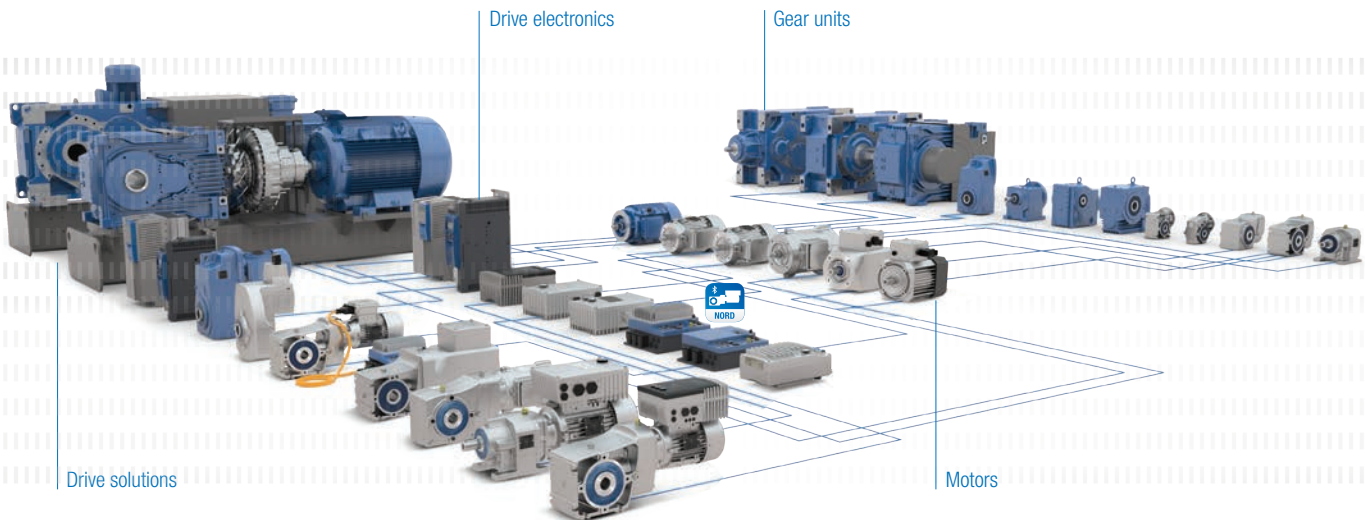

US

NORD Gear Corporation
Waunakee, WI
800 NORD Drive
Waunakee, WI 53597
Tel. 888.314.6673
info.us@nord.com
www.nord.com

Corona, CA
1180 Railroad St.
Corona, CA 92882
Tel. 888.314.6673
info.us@nord.com

Charlotte, NC
300E Forsyth Hall Dr.
Charlotte, NC 28273
Tel. 888.314.6673
info.us@nord.com

CA

NORD Gear Limited
Brampton, ON
41 West Drive
Brampton, ON L6T4A1
Tel. 800.668.4378
info.ca@nord.com

MX

NORD DRIVE SYSTEMS SA DE CV
Queretaro, Mexico
Av. Industria Textil B.6
Parque Industrial PYME, Huimilpan
QRO - Mexico 76950
Tel. 52 442 688 7110
info.mx@nord.com