



Variable frequency drives for decentralized applications

NORDAC *FLEX* SK 200E series



Master of adaptation

NORDAC *FLEX*, SK 200E series



[NORDAC *FLEX*](#)

Variable frequency drives are now essential components of electrical drive technology. They are used for a wide range of automation tasks in many industry fields.

Universal

The NORDAC *FLEX* is an all-around control solution among decentralized VFDs and has established itself across many industries in almost all areas of engineering.

This is due not only to the wide power range (up to 30 HP), but also because of the wide selection of functions and the flexibility offered by its comprehensive range of accessories.

Economical

The NORDAC *FLEX* has been structured with various function levels in order to take efficiency and application-specific requirements into consideration. The series has been arranged into two equipment groups which cover typical conveyor, pump, and fan applications.

Energy-saving

Even for applications in which a frequency drive is not strictly necessary from a technical point of view (constant speed with 60 Hz), the NORDAC *FLEX* beats unregulated drive units with its energy-saving characteristics, particularly in partial load operation.

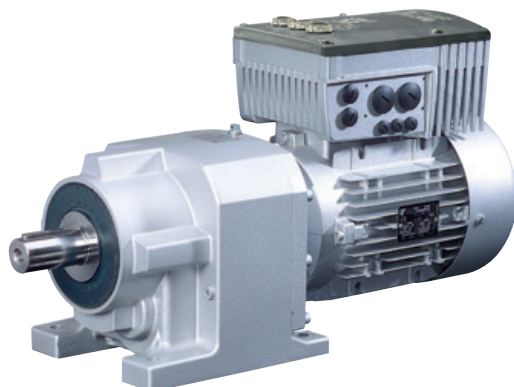

Basic configuration

- Sensorless **current vector control** and **V/f characteristic curve**
- 4 switchable **parameter sets** for flexible use of parameter settings
- All common **drive functions** e.g. acceleration / braking on a ramp, PI controller
- **Parameters** with pre-set standard values
- **POSIICON** for relative and absolute positioning
- **Incremental encoder interface** for speed feedback
- **Stator resistance measurement**
- **PLC functionality** for drive-related functions
- Operation of **three-phase asynchronous motors (ASM)** and **permanent magnet synchronous motors (PMSM)**

Optional

- Interfaces for **8 field bus systems**
- **Various control options** (Potentiometer, control, and parameterization units)
- Versions with **functional safety** (Safe Stop)
- **IO modules** for additional analog and digital inputs and outputs
- **System plug connectors** for power connection of mains and motor cables (industrial plug connectors) as well as for control and signal cables (M12 plug connectors)
- **ATEX versions** for operation in zone 22-3D

Pump/fan applications with the SK 2x0E

1~ 230 V 0.25 - 0.55 kW / 0.33 - 0.50 HP
 3~ 230 V 0.25 - 11 kW / 0.33 - 15 HP
 3~ 400 V 0.55 - 22 kW / 0.50 - 30 HP

Typical requirements

- ▶ Speed setpoints/process signals via analog input, e.g. pressure sensors
- ▶ Stand-alone operation of individual drive units or mobile systems, thanks to integrated control voltage
- ▶ No motor or brake control necessary

Basic configuration SK 2x0E series



4 digital inputs

e.g. for left/right enabling,
fixed frequencies
or parameter set switchover



2 digital outputs

e.g. for reporting errors
or various limit values



1 or 2 analog inputs

e.g. connection for speed setpoint
or process signals



Integrated 24 V power supply

24 V control voltage
for stand-alone operation



Conveyor applications with SK 2x5E (SK 2x0E, Size 4)

1~ 115 V 0.25 - 0.75 kW / 0.33 - 1 HP
 1~ 230 V 0.25 - 1.1 kW / 0.33 - 1.5 HP
 3~ 230 V 0.25 - 4 kW / 0.33 - 5.5 HP
 (11 kW / 15 HP)
 3~ 400 V 0.55 - 7.5 kW / 0.5 - 10 HP
 (22 kW / 30 HP)

Typical requirements

- ▶ Separate voltage levels 400 V / 24 V, e.g. for separate start-up of bus system / control level and power
- ▶ Adjustable brake control with integrated rectifier
- ▶ No processing of analog values required as bus control is frequently used

Basic configuration SK 2x5E series



4 digital inputs

e.g. for left/right enabling,
fixed frequencies or
parameter set switchover



1 digital output

e.g. for reporting errors
or various limit values



Connection for external 24 V power supply

Separate voltage levels for
power and control,
e.g. for separate
start-up or online availability
when the power is switched off



BRE

Integrated brake rectifier

Application and release time optimally
adjustable via parameter

If you are looking for a controlled drive unit

If you are looking for a drive unit with which your machine can perform specific functions

We can supply the optimum device. A drive unit consisting of a combination of series production units that is perfectly tailored to your requirements. A drive unit which can be easily retrofitted with a wide range of accessories to adapt it to changed conditions.

If you have:

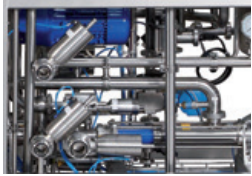

Limited space

- ▶ Restricted installation space in the machine

High performance requirements

- ▶ High-performance drive units
- ▶ High breakaway torques



A need for high-precision speed control

- ▶ Speed fluctuations are not permissible
- ▶ Perfect load take-up (lifting equipment) is required
- ▶ Compensation for fluctuating loads (conveyor belts/conveying equipment)



A need for high-precision positioning

- ▶ Master/follower synchronization
- ▶ Movement to fixed positions (storage and retrieval machines)
- ▶ Movement to relative positions (endless belts in bottling plants)
- ▶ Movement of a drive unit to a changing position of a moving drive system (flying saw)



A need for high flexibility

- ▶ Short time frame in case service is required
- ▶ Frequent changes of machine use
- ▶ Existing motor and gear unit



A need for plug and play

- ▶ For large projects or series production machinery
- ▶ Replacement devices for 1:1 exchange in case of service



A need for sustainability

- ▶ Resource-saving operation
- ▶ Use of products with low levels of hazardous substances



Our solution:

Space-saving

- ▶ A compact device designed with small overall dimensions
- ▶ Integrable optional modules (e.g. interfaces for field bus connection)
- ▶ Wall mounting kits for installation close to the motor



Powerful

- ▶ Unbeatable power range from 0.33 HP to 30 HP
- ▶ Optimized for continuous operation in 4 matching sizes
- ▶ Usable overload reserves of up to 200% of the rated power



Fast

- ▶ Comprehensive measuring methods for recording the actual electrical data as the basis for excellent control of the drive unit
- ▶ Integrated, precise, and fast-acting current vector control for immediate adaptation to actual load conditions
- ▶ Integrated interface for connection of an incremental encoder to detect the actual motor speed (prerequisite for precise control)



Precise

- ▶ Integrated, precise, fast, and completely autonomous positioning function (POSICON)
- ▶ Integrated interface for connection of an absolute encoder to detect the actual position

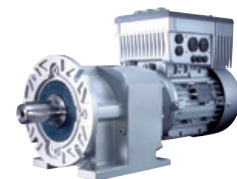

Adaptable

- ▶ Integrated DIP switches for basic configuration without the need for software modification
- ▶ Comprehensive selection of plug connectors for control and power cable connections
- ▶ Easily accessible exchangeable data carrier (EEPROM) for simple exchange of parameter settings between identical devices
- ▶ Devices can also be configured individually



Configurable

- ▶ Mounted on the geared motor
- ▶ Equipped with the necessary accessories (braking resistor, bus interface, encoders, etc.)
- ▶ Pre-parameterized for specific drive applications
- ▶ Equipped with the necessary system plug connectors







Environmentally friendly

- ▶ Low-loss use of energy
- ▶ Energy-saving function to match the power output to the actual demand in partial load operation
- ▶ RoHS compliant





Standards and approvals

All devices of the entire series comply with the standards and directives listed below.

| Approval | Directive | Applied standards | Certificates | Code |
|------------------------|--|------------------------------|------------------------------------|---|
| CE (European Union) | Low Voltage Directive 2014/35/EU | EN 61800-5-1 | C310700 |  |
| | EMC 2014/30/EU | EN 60529 | C310401 | |
| | RoHS 2011/65/EU | EN 61800-3 EN 63000 | | |
| | Delegated directive (EU) 2015/863 | EN 61800-9-1 EN 61800-9-2 | | |
| | Ecodesign 2009/125/EG | | | |
| | Regulation (EU) 2019/1781 Ecodesign | | | |
| UL (USA) | | UL 61800-5-1 | E171342 |  |
| CSA (Canada) | | C22.2 No. 274-13 | E171342 | |
| EAC (Eurasia) | F2018L00028 | EN 61800-3 | 133520966 |  |
| EAC (Eurasia) | TR CU 004/2011, TR CU 020/2011 | IEC 61800-5-1 IEC 61800-3 | EAЭC N RU Д-DE. HB27.B.02727/20 |  |

Devices which are configured and approved for use in explosion hazard environments comply with the following directives and standards.

| Approval | Directive | Applied standards | Certificates | Code |
|------------------------|--|------------------------------|-----------------------------|---|
| CE (European Union) | Low Voltage Directive 2014/35/EU | EN 60079-0 | C432410 |  |
| | EMC 2014/30/EU | EN 60079-31 | | |
| | RoHS 2011/65/EU | EN 61800-5-1 EN 60529 | | |
| | Delegated directive (EU) 2015/863 | EN 61800-3 EN 63000 | | |
| | Ecodesign 2009/125/EG | EN 61800-9-1 EN 61800-9-2 | | |
| | Regulation (EU) 2019/1781 Ecodesign | | | |
| EAC Ex (Eurasia) | TR CU 012/2011 | IEC 60079-0 IEC 60079-31 | TC RU C- DE AA87.B.01109 |  |

Type code

Variable frequency drive - basic device

SK 205E-370-323-A (-C) (xxx)

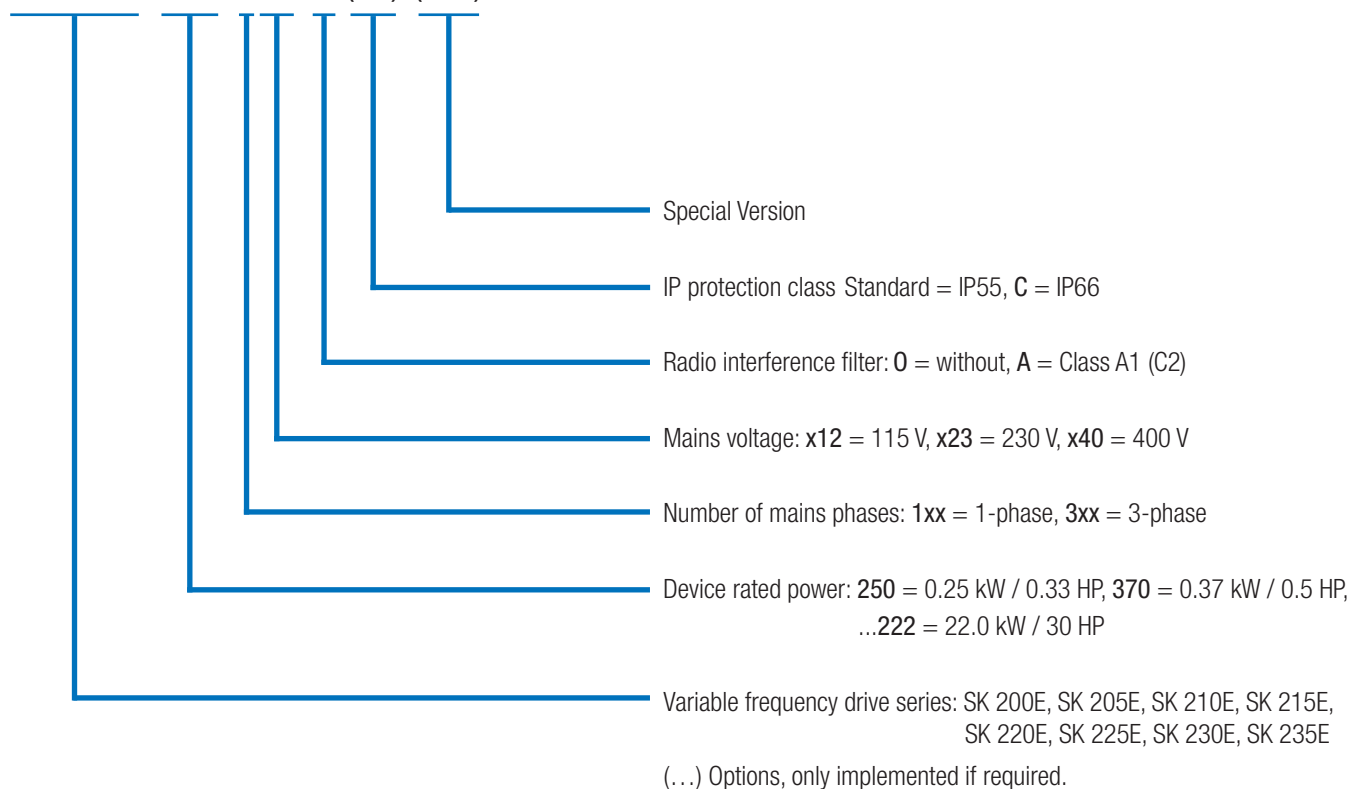

Variable frequency drive - Connection unit

SK TI4-1-205-1 (-C-EX)

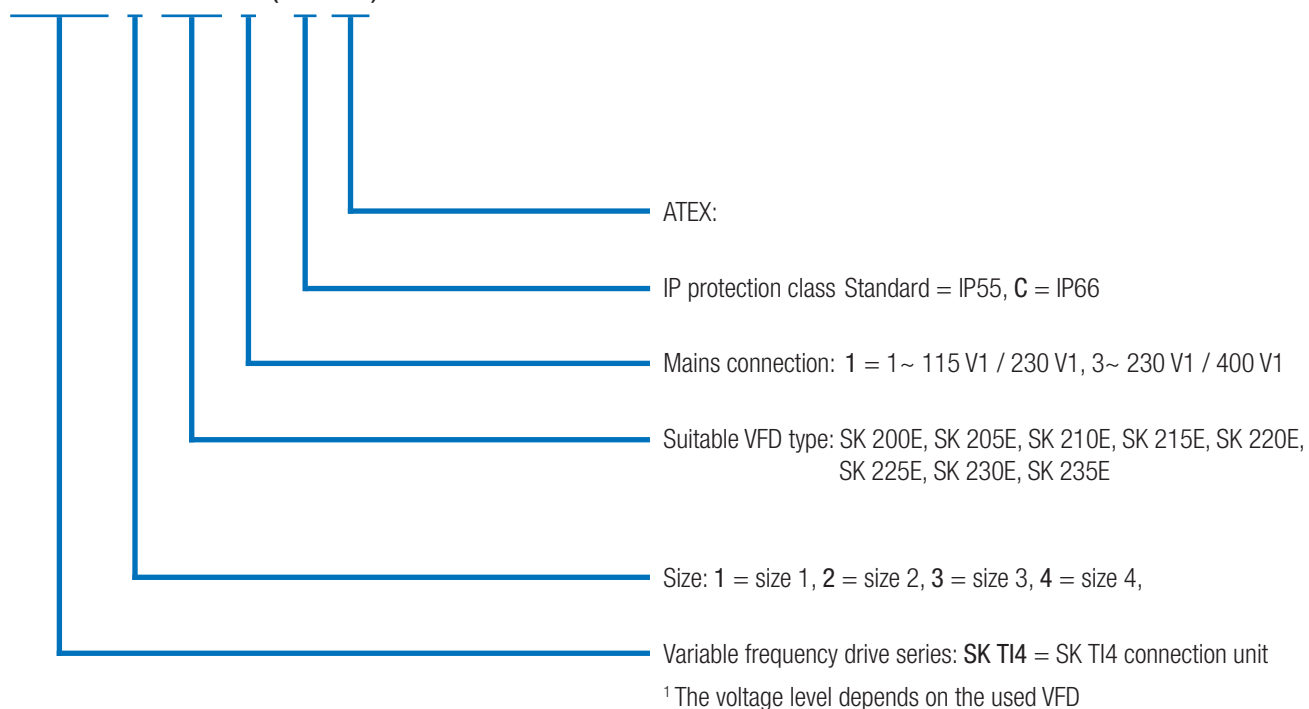

Versatile and sustainable The VFD with servo genes

CANopen®



Standard encoder interfaces

The variable frequency drives' speed control is extremely precise thanks to sophisticated, fast measuring methods and calculation algorithms in combination with integrated high-precision current vector control.

However, there are applications where precision of a thousandth of a motor revolution and very high dynamics (maximum acceleration, cyclic operation, synchronous rotation relative to other drive units) are needed. In such cases, precise feedback from the mechanical momentary values of the motor or the drive unit is required. This feedback is provided by **incremental encoders**, which are normally mounted on the motor shaft and provide information about its actual position. These values enable the motor to be precisely controlled by the frequency drive so that even with large load fluctuations, an asynchronous motor can be operated with a performance similar to that of a servo motor.

Absolute encoders are used when high precision is required in drive applications such as:

- ▶ Synchronization of multiple drive units
- ▶ Dynamic synchronization of a drive unit to a different drive unit (flying saw)
- ▶ Relative positioning tasks (cyclical drives)
- ▶ Absolute positioning tasks (automatic warehouse equipment / high-bay storage, lifting equipment with defined positions)

Each VFD is equipped with a corresponding interface.

- ▶ HTL incremental encoder interface (connection via 2 digital inputs) - primarily for speed control
- ▶ CANopen absolute encoder interface (connection via system bus) - primarily for positioning

Available in all sizes

Modern automation systems



Power
(115 V / 230 V / 400 V)

AS-Interface
including 24 V supply SK 2xxE

Because modern automation systems have a wide range of requirements, a suitable bus system and drive components must be selected to ensure efficient implementation.

The AS-Interface is a cost-effective solution which enables the networking of binary sensors and actuators and is included in certain versions of the NORDAC *FLEX*.

The supply voltage (power) is connected separately via the corresponding terminals. Depending on the version of the device, the control voltage of the VFD is generated either via an integrated power supply unit or separately via the yellow AS-Interface cable. This eliminates the need for an additional AUX cable (black). The type of addressing possible (standard or A/B followers) also depends on the version of the device.

| Device SK ... | 220E/230E | 225E/235E |
|------------------------------|-----------------------|-------------------|
| Follower profile | S-7.A. | S-7.0. |
| Follower type | A/B-Follower | Standard |
| Control voltage | Internal power supply | Yellow AS-I cable |
| Inputs/Outputs | 4/4 | 4/4 |
| Configuration via DIP switch | ● | ● |
| Configuration via parameters | ● | ● |

ATEX-compliant drive systems, zone 22 3D

Size 1-3 devices can be modified for operation in explosive atmospheres. This allows the operation of the variable frequency drive directly in a hazardous area (ATEX 22-3D). The advantages include:

- ▶ Compact drive unit
- ▶ No complex protective devices
- ▶ No motor cables
- ▶ Optimum EMC
- ▶ Permissible characteristic curves 50 Hz / 87 Hz
- ▶ Control range up to 100 Hz or 3000 rpm

Depending on the area of application (conductive or non-conductive dust) the modification includes, among others, replacement of the transparent diagnostic caps with a version made of aluminium and glass.

Operation of the device within the hazard area is only permitted with integrable modules (SK CU4 modules, internal brake resistors) or specially approved accessories (ATEX potentiometer SK ATX-POT).

There are exceptions for SK TU4 modules, which are described in detail in the manual for the device. Other accessories (e.g. external brake resistors, plug connectors) are not approved for use within a hazardous area.



Approval

- ▶ According to 2014/34/EU
- ▶ ATEX Zone 22 - 3D
 - ▶ Version for non-conducting dust: IP55
 - ▶ Version for conducting dust: IP66

Available in all size 1-3 devices



The entire team

All device versions at a glance

| | SK 200E | SK 210E | SK 220E | SK 230E | SK 205E | SK 215E | SK 225E | SK 235E |
|--|------------------------|----------------|----------------|----------------|------------------------|---------|---------|---------|
| | Size 1-4, 0.33 - 30 HP | | | | Size 1-3, 0.33 - 10 HP | | | |
| Motor and wall mounting possible ¹ | ● | ● | ● | ● | ● | ● | ● | ● |
| Energy bus - loop-through of mains supply cables ² | ● | ● | ● | ● | ● | ● | ● | ● |
| Communication bus for various devices ² | ● | ● | ● | ● | ● | ● | ● | ● |
| Sensorless current vector control (ISD control) | ● | ● | ● | ● | ● | ● | ● | ● |
| Brake chopper (brake resistor optional) | ● | ● | ● | ● | ● | ● | ● | ● |
| RS-232 diagnostic interface | ● | ● | ● | ● | ● | ● | ● | ● |
| 4 switchable parameter sets | ● | ● | ● | ● | ● | ● | ● | ● |
| Parameters pre-set with standard values | ● | ● | ● | ● | ● | ● | ● | ● |
| Automatic determination of motor data | ● | ● | ● | ● | ● | ● | ● | ● |
| Energy-saving function, optimized efficiency in partial load operation | ● | ● | ● | ● | ● | ● | ● | ● |
| Integrated EMC line filter according to EN 61800-3, Category C2 up to 5 m motor cable and for motor assembly | ● | ● | ● | ● | ● | ● | ● | ● |
| Extensive monitoring functions | ● | ● | ● | ● | ● | ● | ● | ● |
| Load monitor | ● | ● | ● | ● | ● | ● | ● | ● |
| PI controller | ● | ● | ● | ● | ● | ● | ● | ● |
| Process controller / compensator control | ● | ● | ● | ● | ● | ● | ● | ● |
| Plug-in memory module (EEPROM) | ● | ● | ● | ● | ● | ● | ● | ● |
| Incremental encoder evaluation (speed control) | ● | ● | ● | ● | ● | ● | ● | ● |
| POSICON positioning control | ● | ● | ● | ● | ● | ● | ● | ● |
| PLC functionality | ● | ● | ● | ● | ● | ● | ● | ● |
| Synchronous motor operation (PMSM) | ● | ● | ● | ● | ● | ● | ● | ● |
| Modification for operation in an IT network by means of jumpers | ● | ● | ● | ● | ● | ● | ● | ● |
| All common field bus systems | ● | ● | ● | ● | ● | ● | ● | ● |
| Brake management for mechanical holding brake | ● | ● | ● | ● ³ | ● | ● | ● | ● |
| Lifting gear functionality | ● | ● | ● | ● ³ | ● | ● | ● | ● |
| Safe Stop function (STO, SS1) | ○ | ● | ○ | ● | ○ | ● | ○ | ● |
| AS-Interface on board | ○ | ○ | ● | ● | ○ | ○ | ● | ● |
| Evacuation run | ○ ³ | ○ ³ | ○ ³ | ○ ³ | ● | ● | ● | ● |
| Internal 24 V power supply unit to supply the control board | ● | ● | ● | ● | ● | ● | ● | ● |
| External 24 V power supply for the control board | ● ⁴ | ● ⁴ | ● ⁴ | ● ⁴ | ● | ● | ● | ● |
| Internal / external braking resistors | ● | ● | ● | ● | ● | ● | ● | ● |
| Switch and potentiometer versions | ● | ● | ● | ● | ● | ● | ● | ● |
| Plug connectors for connection of control, motor and mains cables | ● | ● | ● | ● | ● | ● | ● | ● |

¹ Wall mounting: wall mounting kit required
 Motor mounting: an adapter for connection to the motor terminal box may be necessary.

² Direct connection to the terminal bar or via system plug connectors

³ Size 4: standard

⁴ Size 1 -3: no, Size 4: optional

● Available as standard

● Optional

○ Not available

The senses

Control connections on the VFD

| | SK 200E | SK 210E | SK 220E | SK 230E | SK 200E | SK 210E | SK 220E | SK 230E | SK 205E | SK 215E | SK 225E | SK 235E |
|--------------------|--|---------|---------|---------|--------------------|---------|---------|---------|------------------------|---------|---------|---------|
| | Size 1-3, 0.33 - 10 HP | | | | Size 4, 15 - 30 HP | | | | Size 1-3, 0.33 - 10 HP | | | |
| Control terminals | Number of digital inputs (DIN) | 4 | 3 | 4 | 3 | 4 | 3 | 4 | 3 | 4 | 3 | 4 |
| | Fail-safe digital input | ○ | ● | ○ | ● | ○ | ● | ○ | ● | ○ | ● | ○ |
| | Number of digital outputs (DOUT) | 2 | 2 | 2 | 2 | 2 | 2 | 2 | 2 | 1 | 1 | 1 |
| | Number of analog inputs (AIN) ¹ | 2 | 2 | 1 | 1 | 2 | 2 | 2 | 2 | ○ | ○ | ○ |
| | Integrated brake rectifier | ○ | ○ | ○ | ○ | ● | ● | ● | ● | ● | ● | ● |
| | Temperature sensor (PTC) | ● | ● | ● | ● | ● | ● | ● | ● | ● | ● | ● |
| Encoder interfaces | HTL | ● | ● | ● | ● | ● | ● | ● | ● | ● | ● | ● |
| | CANopen ² | ● | ● | ● | ● | ● | ● | ● | ● | ● | ● | ● |
| Communication | RS 485 / RS232 | ● | ● | ● | ● | ● | ● | ● | ● | ● | ● | ● |
| | AS-I | ○ | ○ | ● | ● | ○ | ○ | ● | ● | ○ | ○ | ● |

¹ 0(2) - 10 V, 0(4) - 20 mA
² via system bus

Note

Control terminals can be supplemented by optional modules (IOs, brake management).

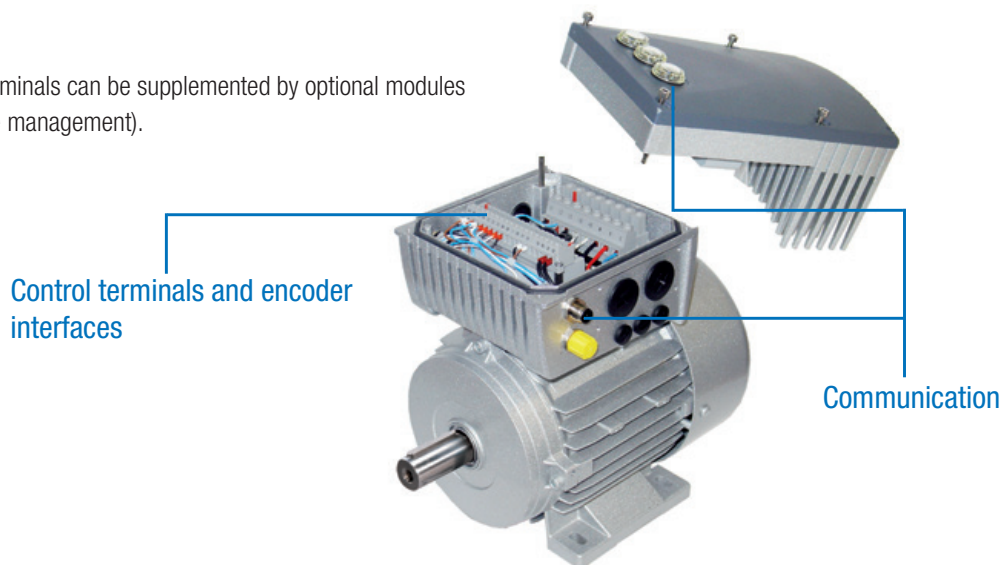

Configuration and monitoring

Integrated aids for safe operation

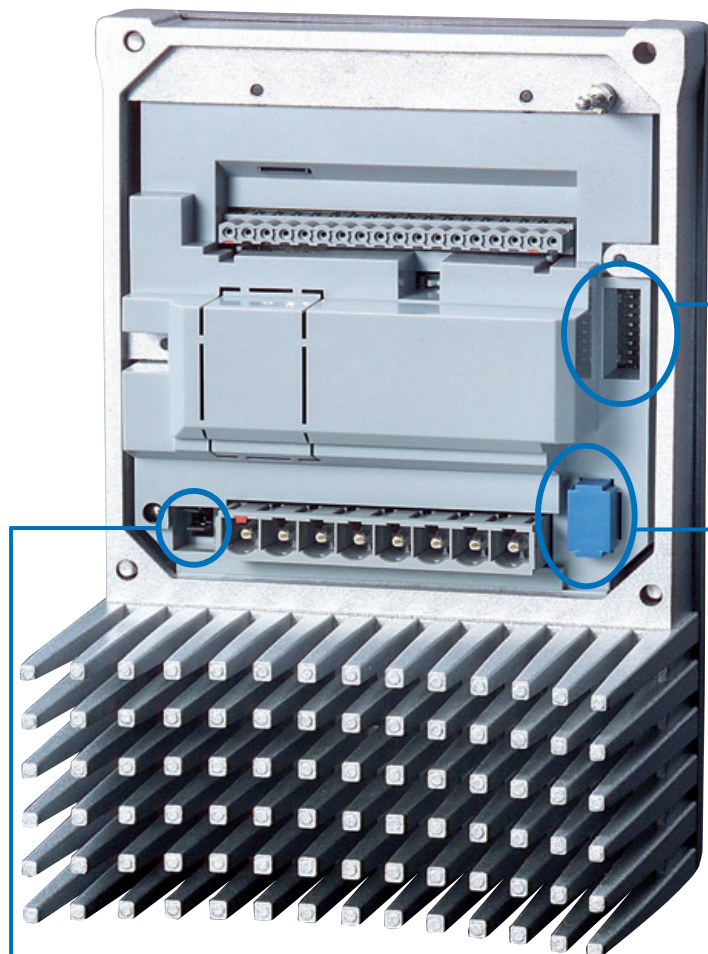

Commissioning with a screwdriver

Various basic functions can be simply set via easily accessible DIP switches so that commissioning is possible without parameterization software. Even when an EEPROM is plugged in, the DIP switch settings have priority over the relevant parameters.



Plug-in EEPROM

The frequency drive is equipped with two EEPROMs for saving individual parameter sets of the device. The primary EEPROM is integrated into the device and the secondary EEPROM is pluggable, allowing for it to be removed/swapped.

Jumpers for mains adaptation

It is possible to adapt the variable frequency drive for operation in an IT network by plugging in a jumper. However, this adaptation has a negative effect on the emission of electromagnetic interference and compliance with the specified degree of radio interference suppression can no longer be guaranteed in this case.

All parameter settings are managed by the internal EEPROM and mirrored to the external EEPROM. The easy access enables data sets to be exchanged between identical drive units via the plug-in EEPROM. Optional parameterization adapter (SK EPG-3H) devices can be parameterized "in the laboratory" so that only the plug-in EEPROM needs to be transferred between the system and the "laboratory".

Status and diagnostic cockpit

Depending on the version, various aids for monitoring the device or diagnostics in case of faults, are located behind 3 transparent cover caps. Additional elements (e.g. DIP switches or similar) are useful for screwdriver-assisted commissioning.

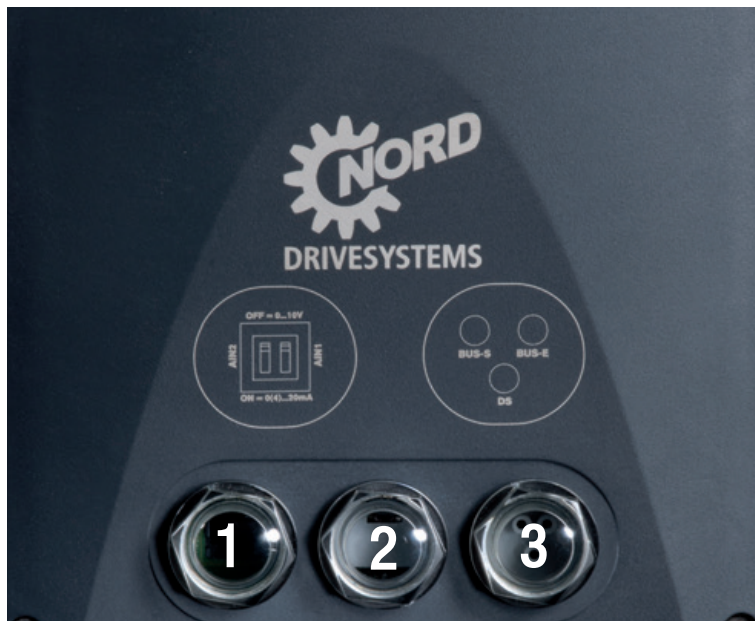

Example: SK 2x0E

SK 2x0E in Sizes 1-3

(Size 4 as for SK 2x5E)

1 Diagnostic interface, RS-232 and RS-485

RJ12 interface for connection of a diagnostic and parameterization tool (e.g. PC with NORDCON software, ParameterBox). Analysis, diagnostics, parameterization, and monitoring of the drive unit via software is possible during commissioning or service.

2 DIP switches for analog inputs

The integrated analog inputs of the device can be configured to the signal form of set point values (current or voltage) via the DIP switches.

3 Status LED for frequency drive and system bus

In addition to status and readiness indicators, the current overload level, warnings, and error messages are indicated in coded form by the LEDs

SK 2x5E and SK 2x0E in Size 4

1 Diagnostic interface, RS-232 and RS-485

RJ12 interface for connection of a diagnostic and parameterization tool (e.g. PC with NORDCON software, ParameterBox). Analysis, diagnostics, parameterization, and monitoring of the drive unit via software is possible during commissioning or service.

2 Status and diagnostic LEDs

In addition to the operating status of the system bus, various signal statuses (e.g. of the digital IOs) can be read here.

3 Potentiometer and status LEDs

The two potentiometers are used for the fixed setting of various dynamic factors (set point frequency, frequency band, acceleration time). The two diagnostic LEDs indicate the operating statuses and error messages of the device or the AS-Interface (if present).

NORDAC FLEX variable frequency drive

1~ 110 ... 120 V and 1/3~ 200 ... 240 V

| | | | |
|----------------------------------|---|-------------------------------------|---|
| Output frequency | 0.0 ... 400.0 Hz | Protection class | IP55, optionally IP66, NEMA1 (higher NEMA classifications on request) |
| Pulse frequency | 3.0 ... 16.0 kHz | Regulation and control | Sensorless current vector control (ISD), linear V/f characteristic curve |
| Typical overload capacity | 150 % for 60 s, 200 % for 3.5 s | Motor temperature monitoring | I ² t Motor PTC / bi-metal switch |
| Energy efficiency class | IE2 | Leakage current | <40 mA for standard configuration of integrated line filter <20 mA for configuration for "operation on IT network" |
| Efficiency | > 95 % | | |
| Ambient temperature | -25 °C ... +50 °C (depending on type of operation) | | |

| VFDs SK 2xxE ... | SK 2x0E | SK 2x5E | Nominal motor power | | Nominal output current rms [A] | Mains voltage | Output voltage |
|---------------------|---------|---------|---------------------|------------|--------------------------------------|--|---|
| | | | 230 V [kW] | 240 V [HP] | | | |
| -250-112-0 (-C) | ○ | ● | 0.25 | 0.33 | 1.7 | 1~ 110 ... 120 V, +/- 10 %, 47 ... 63 Hz | 3~ 0 up to double the mains voltage |
| -370-112-0 (-C) | ○ | ● | 0.37 | 0.5 | 2.2 | | |
| -550-112-0 (-C) | ○ | ● | 0.55 | 0.75 | 3.0 | | |
| -750-112-0 (-C) | ○ | ● | 0.75 | 1 | 4.0 | | |

| VFDs SK 2xxE ... | SK 2x0E | SK 2x5E | Nominal motor power | | Nominal output current rms [A] | Mains voltage | Output voltage |
|---------------------|---------|---------|---------------------|------------|--------------------------------------|---|---------------------------|
| | | | 230 V [kW] | 240 V [HP] | | | |
| -250-123-A (-C) | ○ | ● | 0.25 | 0.33 | 1.7 | 1~ 200 ... 240 V +/-10 % 47 ... 63 Hz | 3 AC 0 – 200 ... 240 V |
| -370-123-A (-C) | ○ | ● | 0.37 | 0.5 | 2.2 | | |
| -550-123-A (-C) | ○ | ● | 0.55 | 0.75 | 3.0 | | |
| -750-123-A (-C) | ○ | ● | 0.75 | 1 | 4.0 | | |
| -111-123-A (-C) | ○ | ● | 1.1 | 1.5 | 5.5 | | |

| VFDs SK 2xxE ... | SK 2x0E | SK 2x5E | Nominal motor power | | Nominal output current rms [A] | Mains voltage | Output voltage |
|---------------------|---------|---------|---------------------|------------|--------------------------------------|--|--------------------------------|
| | | | 230 V [kW] | 240 V [HP] | | | |
| -250-323-A (-C) | ● | ● | 0.25 | 0.33 | 1.7 | 3~ 200 ... 240 V, +/- 10 %, 47 ... 63 Hz | 3~ 0 up to mains voltage |
| -370-323-A (-C) | ● | ● | 0.37 | 0.5 | 2.2 | | |
| -550-323-A (-C) | ● | ● | 0.55 | 0.75 | 3.0 | | |
| -750-323-A (-C) | ● | ● | 0.75 | 1 | 4.0 | | |
| -111-323-A (-C) | ● | ● | 1.1 | 1.5 | 5.5 | | |
| -151-323-A (-C) | ● | ● | 1.5 | 2 | 7.0 | | |
| -221-323-A (-C) | ● | ● | 2.2 | 3 | 9.5 | | |
| -301-323-A (-C) | ● | ● | 3 | 4 | 12.5 | | |
| -401-323-A (-C) | ● | ● | 4 | 5 | 16.0 | | |
| -551-323-A (-C) | ● | ○ | 5.5 | 7.5 | 23.0 | | |
| -751-323-A (-C) | ● | ○ | 7.5 | 10 | 29.0 | | |
| -112-323-A (-C) | ● | ○ | 11 | 15 | 40.0 | | |

IP66 measures

- ▶ Coated aluminium components
- ▶ Coated circuit boards
- ▶ Low-pressure test
- ▶ Diaphragm valve

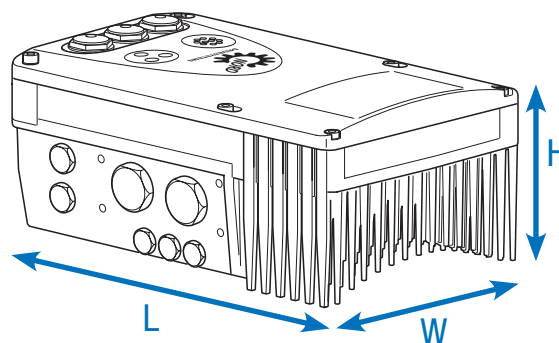

| VFDs SK 2xxE ... | SK 2x0E | SK 2x5E | Weight | | Overall dimensions L x W x H | Size |
|---------------------|---------|---------|--------|-------|--|------|
| | | | [kg] | [lbs] | | |
| -250-112-0 (-C) | ○ | ● | 3.0 | 6.6 | 236 x 156 x 127 mm 9.29 x 6.22 x 5 in | 1 |
| -370-112-0 (-C) | ○ | ● | 3.0 | 6.6 | | 1 |
| -550-112-0 (-C) | ○ | ● | 4.1 | 9 | 266 x 176 x 134 mm | 2 |
| -750-112-0 (-C) | ○ | ● | 4.1 | 9 | 10.47 x 6.93 x 5.28 in | 2 |

| VFDs SK 2xxE ... | SK 2x0E | SK 2x5E | Weight | | Overall dimensions L x W x H | Size |
|---------------------|---------|---------|--------|-------|--|------|
| | | | [kg] | [lbs] | | |
| -250-123-A (-C) | ● | ● | 3.0 | 6.6 | 236 x 156 x 127 mm 9.29 x 6.14 x 5 in | 1 |
| -370-123-A (-C) | ● | ● | 3.0 | 6.6 | | 1 |
| -550-123-A (-C) | ● | ● | 3.0 | 6.6 | | 1 |
| -750-123-A (-C) | ○ | ● | 4.1 | 9 | 266 x 176 x 134 mm | 2 |
| -111-123-A (-C) | ○ | ● | 4.1 | 9 | 10.47 x 6.92 x 5.27 in | 2 |

| VFDs SK 2xxE ... | SK 2x0E | SK 2x5E | Weight | | Overall dimensions L x W x H | Size |
|---------------------|---------|---------|--------|-------|--|------|
| | | | [kg] | [lbs] | | |
| -250-323-A (-C) | ● | ● | 3.0 | 6.6 | 236 x 156 x 127 mm 9.29 x 6.14 x 5 in | 1 |
| -370-323-A (-C) | ● | ● | 3.0 | 6.6 | | 1 |
| -550-323-A (-C) | ● | ● | 3.0 | 6.6 | | 1 |
| -750-323-A (-C) | ● | ● | 3.0 | 6.6 | | 1 |
| -111-323-A (-C) | ● | ● | 3.0 | 6.6 | | 1 |
| -151-323-A (-C) | ● | ● | 4.1 | 9 | 266 x 176 x 134 mm | 2 |
| -221-323-A (-C) | ● | ● | 4.1 | 9 | 10.47 x 6.92 x 5.27 in | 2 |
| -301-323-A (-C) | ● | ● | 6.9 | 15.2 | 330 x 218 x 144 mm | 3 |
| -401-323-A (-C) | ● | ● | 6.9 | 15.2 | 12.99 x 8.58 x 5.66 in | 3 |
| -551-323-A (-C) | ● | ○ | 17.0 | 37.5 | | 4 |
| -751-323-A (-C) | ● | ○ | 17.0 | 37.5 | 480 x 305 x 160 mm 18.89 x 12 x 6.29 in | 4 |
| -112-323-A (-C) | ● | ○ | 17.0 | 37.5 | | 4 |

NORDAC *FLEX* variable frequency drive

3~ 380 ... 500 V

| | | | |
|----------------------------------|---|-------------------------------------|---|
| Output frequency | 0.0 ... 400.0 Hz | Protection class | IP55, optionally IP66, NEMA1 (higher NEMA classifications on request) |
| Pulse frequency | 3.0 ... 16.0 kHz | Regulation and control | Sensorless current vector control (ISD), linear V/f characteristic curve |
| Typical overload capacity | 150 % for 60 s, 200 % for 3.5 s | Motor temperature monitoring | I ² t Motor PTC / bi-metal switch |
| | IE2 | Leakage current | <40 mA for standard configuration of integrated line filter <20 mA for configuration for "operation on IT network" |
| Efficiency | > 95 % | | |
| Ambient temperature | -25 °C ... +50 °C (depending on type of operation) | | |

| VFDs SK 2xxE ... | SK 2x0E | SK 2x5E | Nominal motor power | | Nominal output current rms [A] | Mains voltage | Output voltage |
|---------------------|---------|---------|---------------------|------------|--------------------------------------|---|--------------------------------|
| | | | 400 V [kW] | 480 V [HP] | | | |
| -550-340-A | ● | ● | 0.55 | 0.75 | 1.7 | 3~ 380 ... 500 V, -20 % / +10 %, 47 ... 63 Hz | 3~ 0 up to mains voltage |
| -750-340-A | ● | ● | 0.75 | 1 | 2.3 | | |
| -111-340-A | ● | ● | 1.1 | 1.5 | 3.1 | | |
| -151-340-A | ● | ● | 1.5 | 2 | 4.0 | | |
| -221-340-A | ● | ● | 2.2 | 3 | 5.5 | | |
| -301-340-A | ● | ● | 3.0 | 4 | 7.5 | | |
| -401-340-A | ● | ● | 4.0 | 5 | 9.5 | | |
| -551-340-A | ● | ● | 5.5 | 7.5 | 12.5 | | |
| -751-340-A | ● | ● | 7.5 | 10 | 16.0 | | |
| -112-340-A | ● | ○ | 11.0 | 15 | 23.0 | | |
| -152-340-A | ● | ○ | 15.0 | 20 | 32.0 | | |
| -182-340-A | ● | ○ | 18.5 | 25 | 40.0 | | |
| -222-340-A | ● | ○ | 22.0 | 30 | 46.0 | | |

IP66 measures

- ▶ Coated aluminium components
- ▶ Coated circuit boards
- ▶ Low-pressure test
- ▶ Diaphragm valve

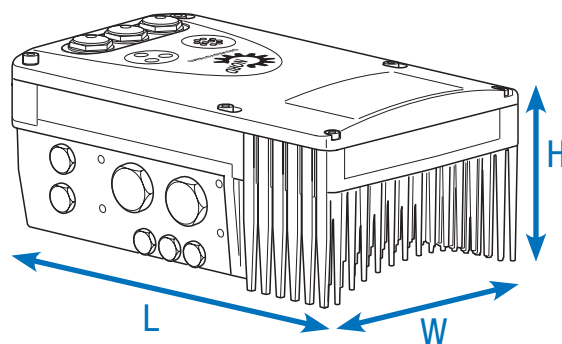

| VFDs SK 2xxE ... | SK 2x0E | SK 2x5E | Weight | | Overall dimensions L x W x H | Size |
|---------------------|---------|---------|--------|-------|--|------|
| | | | [kg] | [lbs] | | |
| -550-340-A | ● | ● | 3.0 | 6.6 | 236 x 156 x 127 mm 9.29 x 6.14 x 5 in | 1 |
| -750-340-A | ● | ● | 3.0 | 6.6 | | 1 |
| -111-340-A | ● | ● | 3.0 | 6.6 | | 1 |
| -151-340-A | ● | ● | 3.0 | 6.6 | | 1 |
| -221-340-A | ● | ● | 3.0 | 6.6 | | 1 |
| -301-340-A | ● | ● | 4.1 | 9 | 266 x 176 x 134 mm | 2 |
| -401-340-A | ● | ● | 4.1 | 9 | 10.47 x 6.92 x 5.27 in | 2 |
| -551-340-A | ● | ● | 6.9 | 15.2 | 330 x 218 x 144 mm 12.99 x 8.58 x 5.66 in | 3 |
| -751-340-A | ● | ● | 6.9 | 15.2 | | 3 |
| -112-340-A | ● | ○ | 17.0 | 37.5 | 480 x 305 x 160 mm 18.89 x 12 x 6.29 in | 4 |
| -152-340-A | ● | ○ | 17.0 | 37.5 | | 4 |
| -182-340-A | ● | ○ | 17.0 | 37.5 | | 4 |
| -222-340-A | ● | ○ | 17.0 | 37.5 | | 4 |

We bring together what belongs together

The NORDAC FLEX

Consists of 2 elements – the actual frequency drive and a suitable connection unit. The connection unit contains all device-specific connection terminals and a space for an optional SK CU4-... module (internal control terminal).



The NORDAC FLEX is typically mounted on a motor and can be combined with motors from various power classes. Depending on the motor and the size and orientation of the VFD, the terminal box may require an additional mounting adapter.

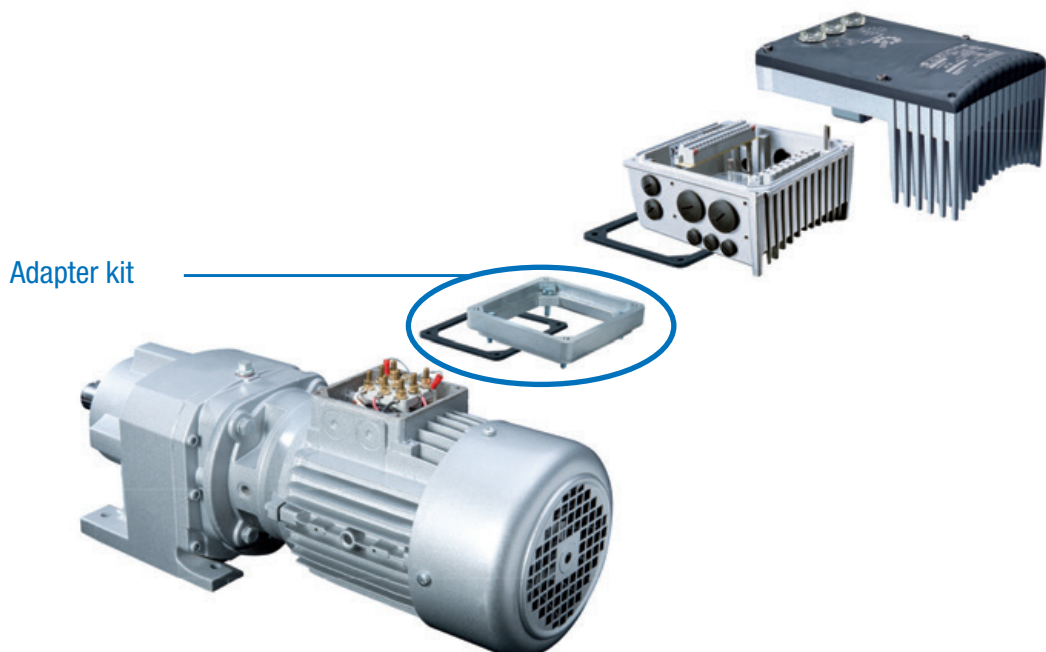

Adjustments for motor mounting

Due to the differences in motors sizes, a terminal box adapter may be necessary. To ensure the device's maximum IPxx protection class for the entire unit, all elements of the drive unit (e.g. motor) must comply with the same protection class.

| Motor size | Attachment SK 2xxE BG 1 | Attachment SK 2xxE BG 2 | Attachment SK 2xxE BG 3 | Attachment SK 2xxE BG 4 |
|------------|-------------------------|-------------------------|-------------------------|-------------------------|
| 63 – 71 | With Adapter Kit I | With Adapter Kit I | Not possible | Not possible |
| 80 – 112 | Direct mounting | Direct mounting | With Adapter Kit II | Not possible |
| 132 | Not possible | Not possible | Direct mounting | With Adapter Kit III |
| 160-180 | Not possible | Not possible | Not possible | Direct mounting |

| Adapter kit designation | Protection class | Designation | Components | Material No. |
|-------------------------|------------------|------------------------------|---|--------------|
| Adapter Kit I | IP55 | TI4-12-Adapterkit_63-71 | Adapter plate, terminal box Frame seal, and screws | 275 119 050 |
| Adapter Kit I | IP66 | SK TI4-12-Adapterkit_63-71-C | | 275 274 324 |
| Adapter Kit II | IP55 | SK TI4-3-Adapterkit_80-112 | Adapter plate, terminal box Frame seal, and screws | 275 274 321 |
| Adapter Kit II | IP66 | SK TI4-3-Adapterkit_80-112-C | | 275 274 325 |
| Adapter Kit III | IP55 | SK TI4-4-Adapterkit_132 | Adapter plate, terminal box Frame seal, and screws | 275 274 320 |
| Adapter Kit III | IP66 | SK TI4-4-Adapterkit_132-C | | 275 274 326 |

Various installation possibilities

Motor Assembly

The VFD can be mounted directly on the terminal box of the (geared) motor, forming an optimized complete unit. This motor-mounted format provides numerous advantages: compact overall dimensions of the drive unit, quick readiness for use after connection to the mains supply due to pre-configuration of the drive unit at the factory, and optimum EMC due to short cable lengths or elimination of a motor cable.

Wall mounting

As an alternative to motor mounting, the device can be mounted close to the motor with the aid of a wall mounting kit. Different versions are available depending on the application.

1. Standard version

SK TIE4-WMK-1-K (-2-K or -3)

Note: If the VFD is wall mounted, the cooling air flow from the motor is not present. This can result in power restrictions (derating) for the frequency drive.

2. Version with fan

SK TIE4-WMK-L-1 (or -L-2)

This version differs from the standard version and includes a fan - ensuring a continuous flow of cooling air over the VFD and avoiding derating due to wall mounting. As a standard, Size 4 variable frequency drives are equipped with fans and do not require a corresponding wall mounting kit.

3. ATEX version

SK TIE4-WMK-1-EX (up to -2-EX)

This version is functionally comparable to the standard version and suitable for use in explosion hazard environments (ATEX Zone 22 3D).

| Designation | Material No. | VFDs ¹ for size FI |
|-----------------------------|--------------|-------------------------------|
| SK TIE4-WMK-1-K | 275 274 004 | 1, 2 |
| SK TIE4-WMK-2-K | 275 274 015 | 3 |
| SK TIE4-WMK-L-1 | 275 274 005 | 1, 2 |
| SK TIE4-WMK-L-1-C | 275 274 016 | 1, 2 |
| SK TIE4-WMK-L-2 | 275 274 006 | 3 |
| SK TIE4-WMK-1-EX | 275 175 053 | 1, 2 |
| SK TIE4-WMK-2-EX | 275 175 054 | 3 |
| SK TIE4-WMK-3 | 275 274 003 | 4 |
| SK TIE4-WMK-TU ² | 275 274 002 | Type: SK TU4- |

¹ Mounting of the WMK on the connection unit of the variable frequency drive

² Mounting of the WMK on the connection unit of the technology unit

Motor-mounted or wall-mounted variable frequency drives

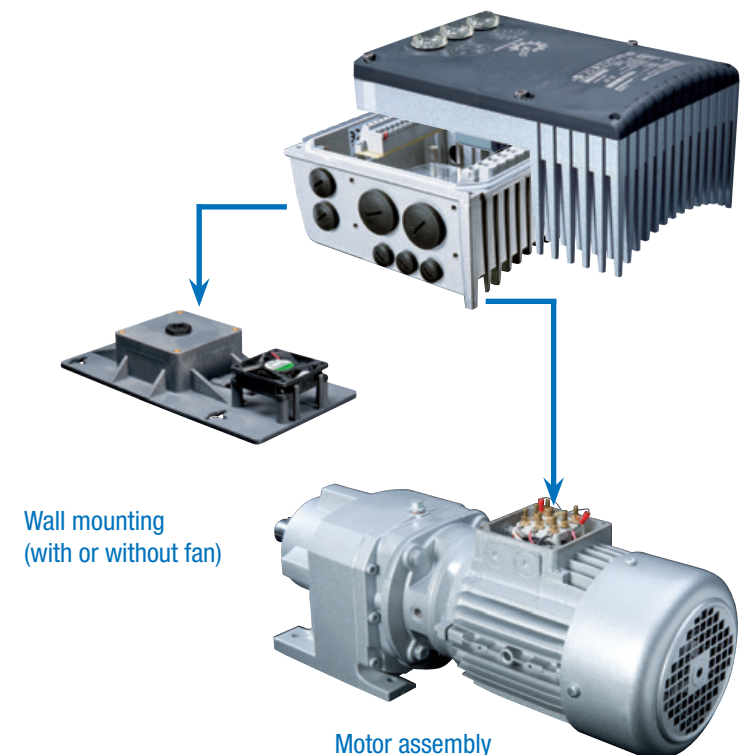

Wall mounting
(with or without fan)

Motor assembly

| Designation | Material | Integrated fan | Achievable protection class | Weight | Overall dimensions L x W x H | Remarks |
|-------------------|-----------------|----------------|-----------------------------|--------------------|---|-----------------------------|
| SK TIE4-WMK-1-K | Plastic | ○ | IP66 | 0.2 kg 0.44 lbs | 205 x 95 x 5 mm 8.07 x 3.74 x 0.19 in | Note: derating as necessary |
| SK TIE4-WMK-2-K | Plastic | ○ | IP66 | 0.3 kg 0.66 lbs | 235 x 105 x 5 mm 9.25 x 4.13 x 0.19 in | Note: derating as necessary |
| SK TIE4-WMK-L-1 | Plastic | ● | IP55 | 0.4 kg 0.88 lbs | 255 x 130 x 24 mm 10.03 x 5.11 x 0.94 in | Fan power: 24 V DC, 1.3 W |
| SK TIE4-WMK-L-1-C | Plastic | ● | IP66 | 0.4 kg 0.88 lbs | 255 x 130 x 24 mm 10.03 x 5.11 x 0.94 in | Fan power: 24 V DC, 1.3 W |
| SK TIE4-WMK-L-2 | Plastic | ● | IP55 | 0.5 kg 1.1 lbs | 300 x 150 x 30 mm 11.8 x 5.9 x 1.18 in | Note: derating as necessary |
| SK TIE4-WMK-1-EX | Stainless steel | ○ | IP66 | 0.6 kg 1.32 lbs | 205 x 95 x 4 mm 8.07 x 3.74 x 0.15 in | Note: derating as necessary |
| SK TIE4-WMK-2-EX | Stainless steel | ○ | IP66 | 0.8 kg 1.76 lbs | 235 x 105 x 10 mm 9.25 x 4.13 x 0.39 in | Note: derating as necessary |
| SK TIE4-WMK-3 | Stainless steel | ○ | IP66 | 2.4 kg 5.29 lbs | 295 x 255 x 8 mm 11.6 x 10 x 0.31 in | |
| SK TIE4-WMK-TU | Stainless steel | ○ | IP66 | 0.4 kg 0.88 lbs | 155 x 85 x 3 mm 6.10 x 3.35 x 0.12 in | |

¹ H = increase in the total height of the device if mounted on the wall mounting kit

Technology unit on NORDAC FLEX or wall mounting

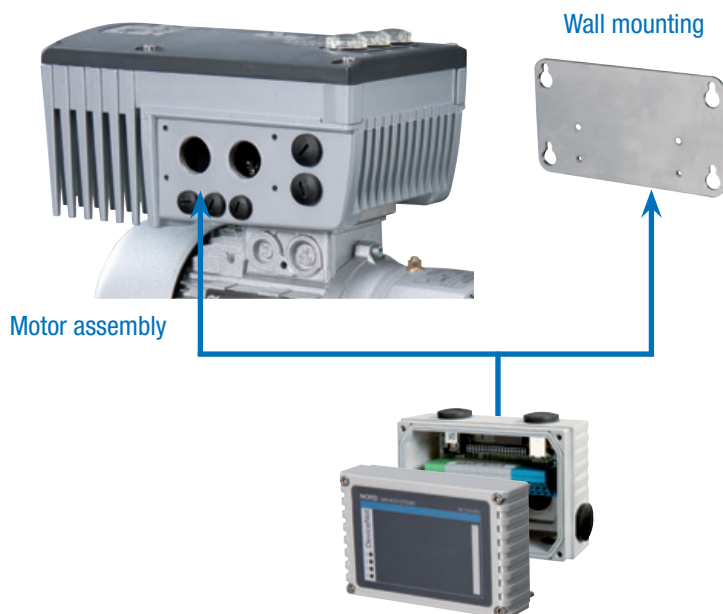

Brake resistors

Internal version

Internal braking resistors SK BRI4

Internal braking resistors are intended for applications in which slight or only sporadic, brief braking is to be expected (e.g. continuous conveyor equipment, mixing equipment). They also enable the use of the variable frequency drive in very confined spaces or in an explosive atmosphere.

Internal brake resistors are intended for installation in the connection unit of the VFD. The devices provide space for the integration of one brake resistor or a set of 2 brake resistors (SK 2x0E, size 4). For thermal reasons, the rated continuous output is limited to 25%. A respective overload protection can be configured via DIP switch.

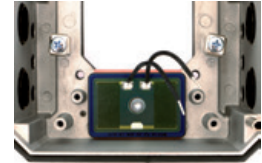

| VFDs SK 2xxE ... | Resistor type | Material No. | Resistance [Ω] | Continuous output [W] | Power consumption ² [kW] | |
|---------------------|-------------------------------------|-------------------|-------------------|-----------------------------|---|-----|
| 1 ~ 115 V | 0.25 ... 0.75 kW 0.33 ... 1.0 HP | SK BRI4-1-100-100 | 275 272 005 | 100 | 100 / 25 % | 1,0 |
| | 0.25 ... 1.1 kW 0.33 ... 1.5 HP | SK BRI4-1-100-100 | 275 272 005 | 100 | 100 / 25 % | 1,0 |
| 1 ~ 230 V | 0.25 ... 2.2 kW 0.33 ... 3.0 HP | SK BRI4-1-200-100 | 275 272 008 | 200 | 100 / 25 % | 1,0 |
| | 3.0 ... 4.0 kW 4.0 ... 5.5 HP | SK BRI4-2-100-200 | 275 272 105 | 100 | 200 / 25 % | 2,0 |
| | 5.5 ... 7.5 kW | SK BRI4-3-047-300 | 275 272 201 | 47 | 300 / 25 % | 3,0 |
| | 11 kW 15 HP | SK BRI4-3-023-600 | 275 272 800 | 23 | 600 / 25 % | 6,0 |
| 3 ~ 230 V | 0.55 ... 4.0 kW 0.75 ... 5.5 HP | SK BRI4-1-400-100 | 275 272 012 | 400 | 100 / 25 % | 1,0 |
| | 5.5 ... 7.5 kW 7.5 ... 10 HP | SK BRI4-2-200-200 | 275 272 108 | 200 | 200 / 25 % | 2,0 |
| | 11 ... 15 kW 15 ... 20 HP | SK BRI4-3-100-300 | 275 272 205 | 100 | 300 / 25 % | 3,0 |
| | 8.5 ... 22 kW 25 ... 30 HP | SK BRI4-3-050-600 | 275 272 801 | 50 | 600 / 25 % | 6,0 |

¹ Reduction of the continuous output of the braking resistor to 25% of the rated output

² Permissible max. once within 10 s

Braking resistors

External version

External braking resistors SK BRE4

External braking resistors (IP67) are intended for applications in which longer, frequent or intensive braking is to be expected (cyclic operation/high dynamic positioning applications). They are mounted directly on the VFD and can develop high surface temperatures (>70 °C), which exclude their use in an explosive atmosphere.

Note:

The braking resistors listed here are designed for typical applications with occasional braking. In case of doubt or for applications with higher braking power such as lifting equipment, we recommend specific planning of the necessary brake resistor and contacting NORD DRIVESYSTEMS directly.

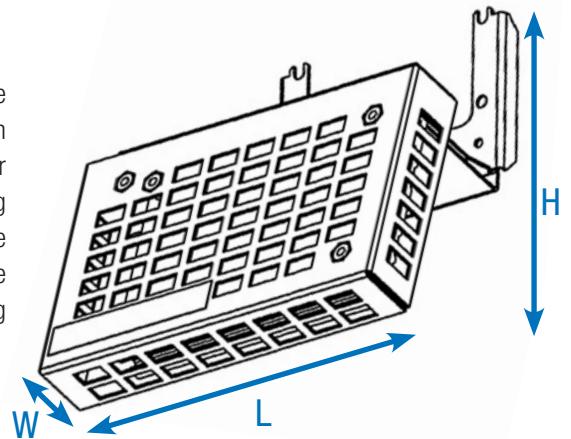

| VFDs SK 2xxE ... | Resistor type Material No. | Resistance [Ω] | Continuous output [W] | Power consumption ² [kW] | Overall dimensions L x W x H |
|--|--|-------------------|-----------------------------|---|---|
| 1 ~ 115 V 0.25 ... 0.75 kW 0.33 ... 1.0 HP | SK BRE4-1-100-100 275 273 005 | 100 | 100 | 2.2 | 150 x 61 x 178 mm 5.90 x 2.40 x 7 in |
| | Alternatively: SK BRE4-2-100-200 275 273 105 | 100 | 200 | 4.4 | 255 x 61 x 178 mm 10.03 x 2.40 x 7 in |
| 1 ~ 230 V 0.25 ... 1.1 kW 0.33 ... 1.5 HP | SK BRE4-1-100-100 275 273 005 | 100 | 100 | 2.2 | 150 x 61 x 178 mm 5.90 x 2.40 x 7 in |
| | Alternatively: SK BRE4-2-100-200 275 273 105 | 100 | 200 | 4.4 | 255 x 61 x 178 mm 10.03 x 2.40 x 7 in |
| 3 ~ 230 V 0.25 ... 2.2 kW 0.33 ... 3.0 HP | SK BRE4-1-200-100 275 273 008 | 200 | 100 | 2.2 | 150 x 61 x 178 mm 5.90 x 2.40 x 7 in |
| | Alternatively: SK BRE4-2-200-200 275 273 108 | 200 | 200 | 4.4 | 255 x 61 x 178 mm 10.03 x 2.40 x 7 in |
| | SK BRE4-2-100-200 275 273 105 | 100 | 200 | 4.4 | 255 x 61 x 178 mm 10.03 x 2.40 x 7 in |
| | SK BRE4-3-050-450 275 273 201 | 50 | 450 | 3.0 | 355 x 245 x 318 mm 13.97 x 9.6 x 12.5 in |
| 3 ~ 400 V 0.55 ... 4.0 kW 0.75 ... 5.5 HP | SK BRE4-1-400-100 275 273 012 | 400 | 100 | 2.2 | 150 x 61 x 178 mm 5.90 x 2.40 x 7 in |
| | Alternatively: SK BRE4-2-200-200 275 273 108 | 200 | 200 | 4.4 | 255 x 61 x 178 mm 10.03 x 2.40 x 7 in |
| | SK BRE4-2-200-200 275 273 108 | 200 | 200 | 4.4 | 255 x 61 x 178 mm 10.03 x 2.40 x 7 in |
| | SK BRE4-3-100-450 275 273 205 | 100 | 450 | 3.0 | 355 x 245 x 318 mm 13.97 x 9.6 x 12.5 in |

¹ Permissible max. once within 120 s

US

NORD Gear Corporation
Waunakee, WI
800 NORD Drive
Waunakee, WI 53597
Tel. 888.314.6673
info.us@nord.com
www.nord.com

Corona, CA
1180 Railroad St.
Corona, CA 92882
Tel. 888.314.6673
info.us@nord.com

Charlotte, NC
300E Forsyth Hall Dr.
Charlotte, NC 28273
Tel. 888.314.6673
info.us@nord.com

CA

NORD Gear Limited
Brampton, ON
41 West Drive
Brampton, ON L6T4A1
Tel. 800.668.4378
info.ca@nord.com

MX

NORD DRIVE SYSTEMS SA DE CV
Queretaro, Mexico
Av. Industria Textil B.6
Parque Industrial PYME, Huimilpan
QRO - Mexico 76950
Tel. 52 442 688 7110
info.mx@nord.com