

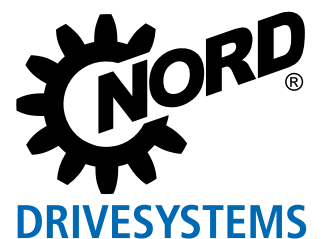

# Frequency inverter for control cabinet application

NORDAC *PRO* SK 500E series



# Powerful and versatile NORDAC *PRO*, SK 500E series



[NORDAC \*PRO\* - SK500E](#)

NORDAC *PRO* SK 500E frequency inverters are available for motors with rated powers of 0.25 – 160 kW. With a very compact design they are perfect for space-saving installation in control cabinets.

Notable features across the entire product line include:

- ▶ Sensorless current vector control which ensures constant speeds in case of fluctuating loads and very high torques during start-up
- ▶ 200% overload reserve which provides greater operational safety in cranes and lifting gear applications
- ▶ Operation of asynchronous and synchronous motors
- ▶ Integrated brake chopper for 4-quadrant operation
- ▶ Integrated line filter as the basis for optimal EMC performance

These features are as much a part of the basic configuration as the separately configurable PID or the process controller. These controllers independently carry out the control tasks in your application. The range is supplied with either an integrated 24 V power supply unit or a separate connection for the control board supply.

The advantage of externally powered frequency inverters is that access to parameter data and communication through any bus interfaces is possible even when the power is switched off. Moreover, an evacuation run controlled by the inverter can be performed, which constitutes an enormous boost in safety for lifting gear and similar safety-critical drive applications.

The SK 51xE and SK 530E and SK 535E models support the Safe Stop function according to EN 13849-1 (up to the maximum safety category 4, stop category 0 and 1). In addition, the SK 53xE version equipped with the built-in POSICON function makes it ideally suitable for all types of positioning tasks (relative and absolute). As standard, an integrated PLC on all SK 520E models and higher allows simple and free programming of drive-related functions in accordance with IEC 61131-3. In addition, the top model SK 540E/SK 545E features a universal encoder interface which allows connection of SSI or EnDat encoders. The frequency inverters maintain uniform dimensions even with the different functional configurations.



## Basic configuration

- Sensorless current vector control (ISD control) for high precision control and fast response times
- Brake management, electromechanical holding brake
- Brake chopper to divert generated energy to a brake resistor
- RS-232 diagnostic interface
- 4 switchable parameter sets for flexible use of parameter settings (e.g. switching between drive units with different motor data)
- All common drive functions such as acceleration/braking on a ramp
- Parameters pre-set with standard values, hence immediately ready for use
- Scalable display values
- Stator resistance measurement to ensure optimal control characteristics









## Optional

- Interfaces for many bus systems
- Various control options (switches, potentiometers or parameterisation units)
- Variants with functional safety (Safe Stop (STO, SS1))  
[Available for SK 510E and above](#)  
[\(except for frequency inverters with mains voltages <230 V AC\)](#)
- Variants with incremental encoder interface for speed feedback (servo mode)  
[Available for SK 520E and higher](#)
- Variants with PLC functionality  
[Available for SK 520E and higher](#)
- POSICON variants with positioning function (relative and absolute)  
[Available for SK 530E and higher](#)
- Universal encoder interface  
[Available for SK 540E and higher](#)



# Standards and approvals

All devices of the entire series comply with the standards and directives listed below.

Approval	Directive	Applied standards	Certificates	Code
CE (European Union)	Low Voltage Directive 2014/35/EU	EN 61800-5-1 EN 60529	C310600	
	EMC 2014/30/EU	EN 61800-3 EN 63000		
	RoHS 2011/65/EU	EN 61800-9-1 EN 61800-9-2		
	Delegated directive (EU) 2015/863			
	Ecodesign 2009/125/EG			
	Regulation (EU) Ecodesign 2019/1781			
UL (USA)		UL 508C	E171342	
CSA (Canada)		C22.2 No.274-13	E171342	
RCM (Australia)	F2018L00028	EN 61800-3	133520966	
EAC (Eurasia)	TR CU 004/2011, TR CU 020/201	IEC 61800-5-1 IEC 61800-3	N RU Д-DE. HB27.B.02721/ 20	
UkrSEPRO (Ukraine)		EN 61800-5-1 EN 60529 EN 61800-3 EN 63000 EN 60947-1 EN 60947-4 EN 61558-1 EN 50581	C311900	
UKCA (United Kingdom)		EN 61800-5-1 EN 60529 EN 61800-3 EN 63000 EN 61800-9-1 EN 61800-9-2	C350600	

# Type code

## Frequency inverters

### SK 530E-370-323-A(-CP)

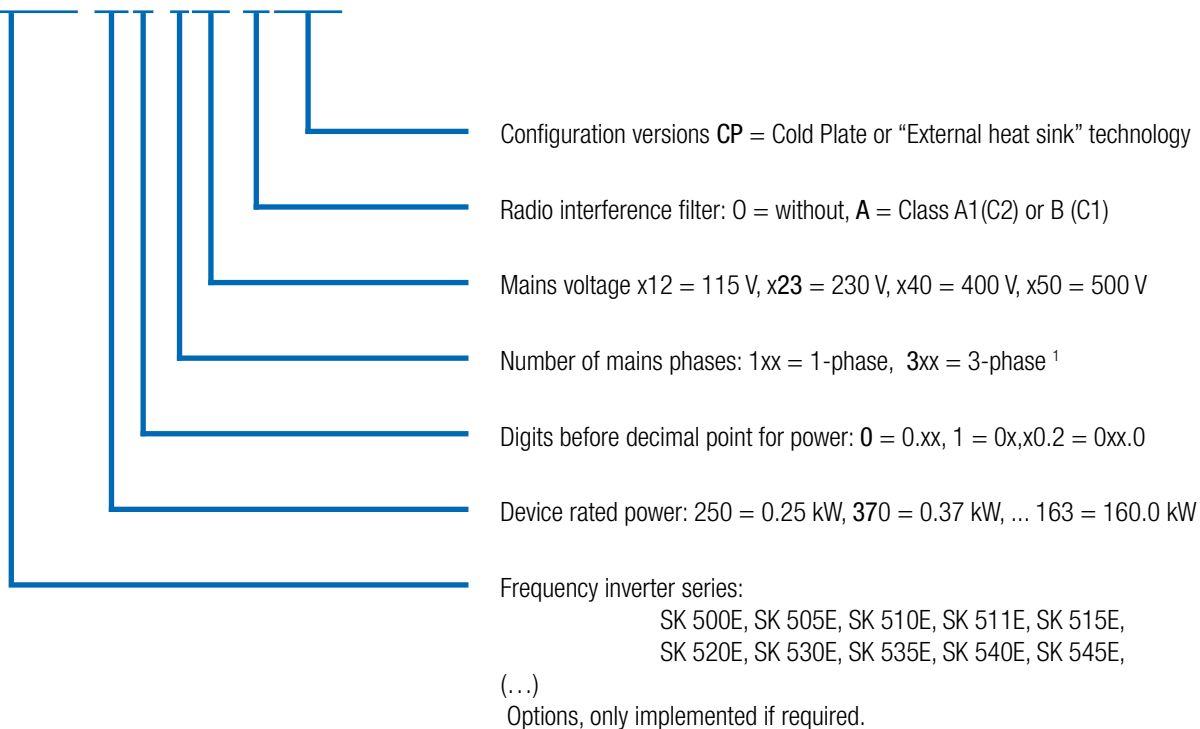

<sup>1</sup> Designation -3 also includes combined devices which are intended for single and three-phase operation (please refer to the technical data)

## Technologieboxen

### SK TU3-PNT(-...)

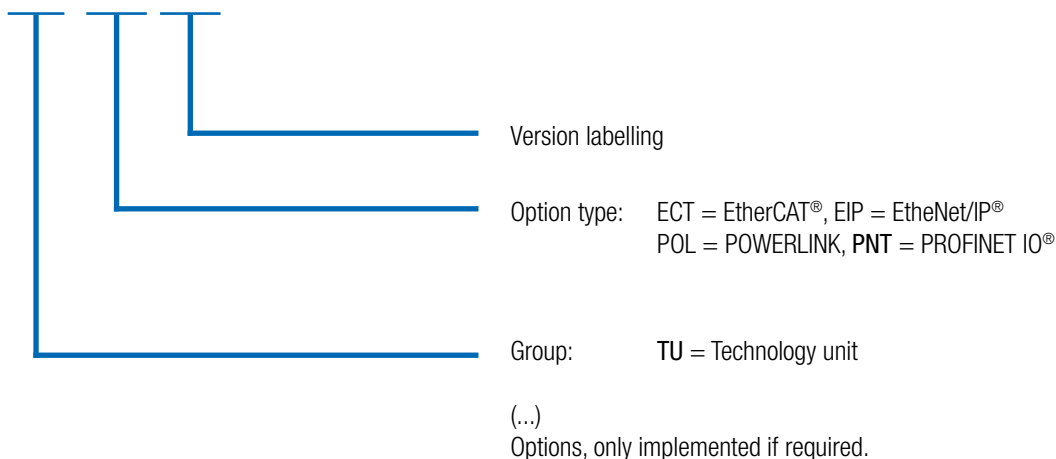

# NORDAC PRO SK 500E

## All versions at a glance

	SK 500E	SK 510E	SK 511E	SK 520E	SK 530E	SK 535E	SK 540E	SK 545E	SK 515E	SK 535E	SK 545E
	Size 1-4								Size 5-11		
Sensorless current vector control (ISD control)	●	●	●	●	●	●	●	●	●	●	●
Brake management for mechanical holding brake	●	●	●	●	●	●	●	●	●	●	●
Brake chopper (brake resistor optional)	●	●	●	●	●	●	●	●	●	●	●
RS-232 diagnostic interface	●	●	●	●	●	●	●	●	●	●	●
4 switchable parameter sets	●	●	●	●	●	●	●	●	●	●	●
All normal drive functions	●	●	●	●	●	●	●	●	●	●	●
Parameters pre-set with standard values	●	●	●	●	●	●	●	●	●	●	●
Stator resistance measurement	●	●	●	●	●	●	●	●	●	●	●
Energy-saving function, optimised efficiency in partial load operation	●	●	●	●	●	●	●	●	●	●	●
Integrated EMC line filter according to EN 61800-3, Category C2 up to 20 m motor cable, Category C1 up to 5 m motor cable (devices up to Size 4)	●	●	●	●	●	●	●	●	●	●	●
Monitoring functions	●	●	●	●	●	●	●	●	●	●	●
Load monitor	●	●	●	●	●	●	●	●	●	●	●
Link circuit coupling	●	●	●	●	●	●	●	●	●	●	●
Lifting gear functionality	●	●	●	●	●	●	●	●	●	●	●
PID controller	●	●	●	●	●	●	●	●	●	●	●
Process controller / compensator control	●	●	●	●	●	●	●	●	●	●	●
Synchronous motor operation (PMSM)	●	●	●	●	●	●	●	●	●	●	●
Cold plate up to Size 4, External heat sink technology up to Size 2	●	●	●	●	●	●	●	●	○	○	○
All common field bus systems	●	●	●	●	●	●	●	●	●	●	●
"Safe Stop" function (STO, SS1) (not for 115 V devices)	○	●	●	○	●	●	●	●	●	●	●
CANopen® on board	○	○	●	●	●	●	●	●	●	●	●
Evacuation run	○	○	○	○	○	●	●	●	●	●	●
Incremental encoder input (servo mode)	○	○	○	●	●	●	●	●	○	●	●
POSICON	○	○	○	○	●	●	●	●	○	●	●
Internal 24 V power supply unit to supply the control board	●	●	●	●	●	○	●	○	●	●	●
External 24 V power supply for the control board	○	○	○	○	○	●	○	●	●	●	●
Automatic switching between external and internal 24 V control voltage	○	○	○	○	○	○	○	○	●	●	●
PLC functionality	○	○	○	●	●	●	●	●	○	●	●
Universal encoder interface	○	○	○	○	○	○	●	●	○	○	●

- Available as standard
- Optional
- Not available



	SK 500E	SK 510E	SK 511E	SK 520E	SK 530E	SK 535E	SK 540E	SK 545E	SK 515E	SK 535E	SK 545E	
	Size 1-4								Size 5-11			
Control terminals	DIN	5	5	5	7	7	7	5-7 <sup>1</sup>	5-7 <sup>1</sup>	5	7	6-8 <sup>1</sup>
	DOUT	0	0	0	2	2	2	3-1 <sup>1</sup>	3-1 <sup>1</sup>	0	2	3-1 <sup>1</sup>
	Signal relay <sup>2</sup> (... 230 V AC, 2 A)	2	2	2	2	2	2	2	2	2	2	2
	AIN <sup>3</sup>	2	2	2	2	2	2	2	2	2	2	2
	AOUT <sup>3</sup>	1	1	1	1	1	1	1	1	1	1	1
	TF (PTC)	1 <sup>4</sup>	1 <sup>4</sup>	1 <sup>4</sup>	1 <sup>4</sup>	1 <sup>4</sup>	1 <sup>4</sup>	1	1	1	1	1
Encoder interfaces	TTL RS422	○	○	○	●	●	●	●	●	○	●	●
	HTL <sup>4,5</sup>	●	●	●	●	●	●	●	●	●	●	●
	CANopen®	○	○	○	○	●	●	●	●	○	●	●
	SIN / COS	○	○	○	○	○	○	●	●	○	○	●
	SSI	○	○	○	○	○	○	●	●	○	○	●
	BISS	○	○	○	○	○	○	●	●	○	○	●
	Hiperface	○	○	○	○	○	○	●	●	○	○	●
	Endat 2.1	○	○	○	○	○	○	●	●	○	○	●
	CAN / CANopen®	○	○	2	2	2	2	2	2	2	2	2
Communication	RS-485 / RS-232	1	1	1	1	1	1	1	1	1	1	1
	RS-485	○	○	○	1	1	1	1	1		1	1
	Modbus RTU	●	●	●	●	●	●	●	●	●	●	●

- <sup>1</sup> 2 digital IOs optionally parameterisable as DIN or DOUT
- <sup>2</sup> Parameterisable with DOUT functions
- <sup>3</sup> AIN/AOUT can also be used for digital signals.  
AIN: 0(2) – 10 V, 0(4) – 20 mA, size 5 and above additionally ± 10 V
- <sup>4</sup> Function can only be implemented through a digital input,
- <sup>5</sup> speed control only available with SK 520E or higher.

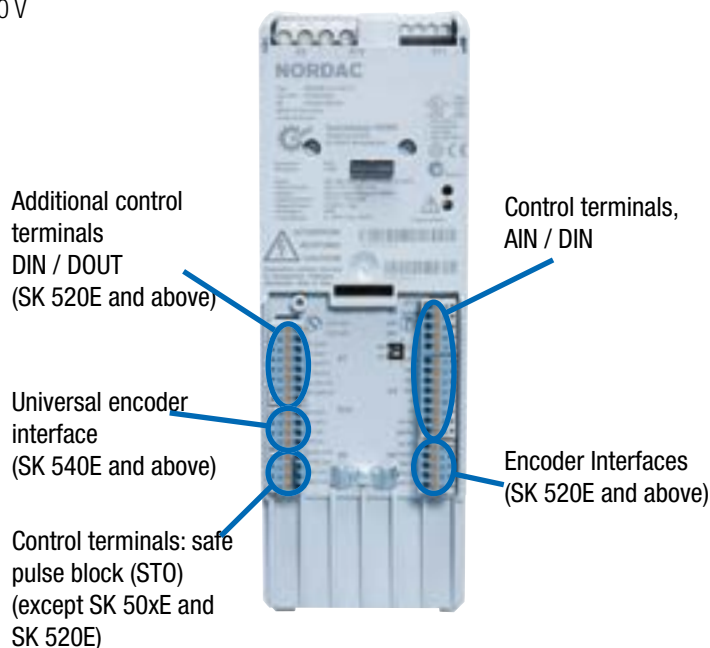
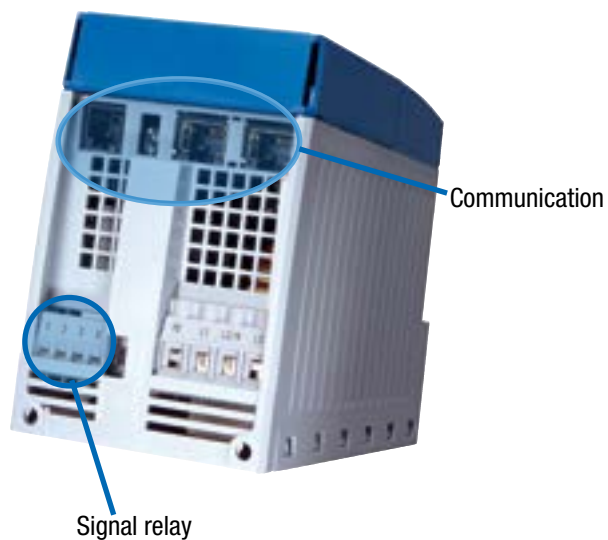

# NORDAC *PRO* SK 500E frequency inverter

## 1~ 110 ... 120 V und 1 / 3~ 200 ... 240 V

<b>Output frequency</b>	0.0 ... 400.0 Hz	<b>Protection class</b>	IP20
<b>Pulse frequency</b>	3.0 ... 16.0 kHz	<b>Regulation and control</b>	Sensorless current vector control (ISD), linear V/f characteristic curve
<b>Typical overload capacity</b>	150 % for 60 s, 200 % for 3.5 s	<b>Motor temperature monitoring</b>	I <sup>2</sup> t Motor PTC / bi-metal switch
<b>Energy efficiency class</b>	IE2	<b>Leakage current</b>	<30 mA, may be considerably less depending on the size and configuration of the frequency inverter (refer to the manual for details)
<b>Frequency inverter efficiency</b>	Size 1 -4 approx. 95 % Size 5 -7 approx. 97 % Size 8 -11 approx. 98 %		
<b>Ambient temperature</b>	0 °C ... +40 °C (S1) 0 °C ... +50 °C (S3, -70 % ED)		

Frequency inverters SK 5xxE ...	Nominal motor power		Nominal output current rms [A]	Mains voltage	Output voltage
	230 V [kW]	240 V [hp]			
-250-112-0	0.25	1/3	1.7	1~ 110 ... 120 V. +/- 10 %. 47 ... 63 Hz	3~ 0 - 2x mains voltage
-370-112-0	0.37	1/2	2.2		
-550-112-0	0.55	3/4	3.0		
-750-112-0	0.75	1	4.0		
-111-112-0	1.1	1 1/2	5.3		

Frequency inverters SK 5xxE ...	Nominal motor power		Nominal output current rms [A]	Mains voltage	Output voltage
	230 V [kW]	240 V [hp]			
-250-323-A	0.25	1/3	1,7	1 / 3~ 200 ... 240 V, +/- 10 %, 47 ... 63 Hz	3~ 0 up to mains voltage
-370-323-A	0.37	1/2	2,2		
-550-323-A	0.55	3/4	3,0		
-750-323-A	0.75	1	4,0		
-111-323-A	1.1	1 1/2	5,5		
-151-323-A	1.5	2	7,0		
-221-323-A	2.2	3	9,5		
-301-323-A	3.0	4	12,5		
-401-323-A	4.0	5	16,0		
-551-323-A	5.5	7 1/2	22.0		
-751-323-A	7.5	10	28.0		
-112-323-A	11.0	15	46.0		
-152-323-A	15.0	20	60.0		
-182-323-A	18.5	25	73.0		



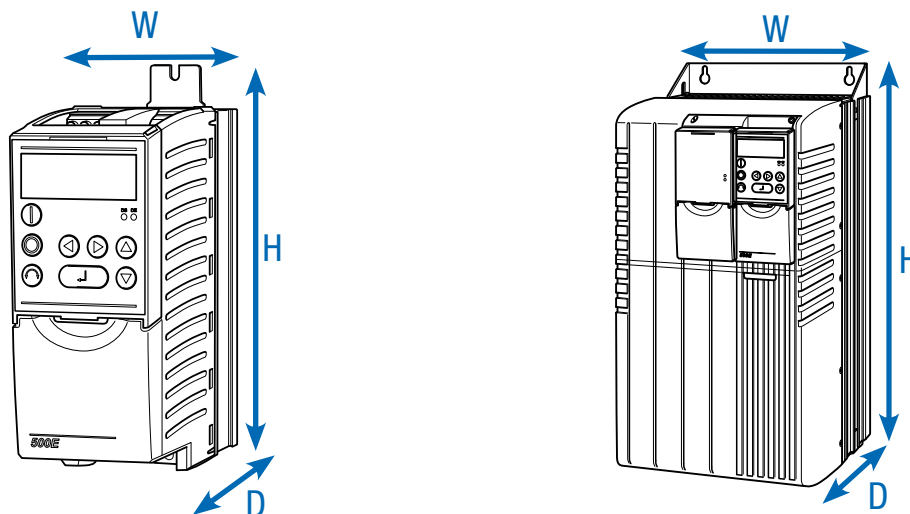

Frequency inverters SK 5xxE ...	Weight [kg]	(Overall) dimensions H x W x D [mm]	Size
-250-112-0	1.4	220 x 74 x 153	1
-370-112-0	1.4	220 x 74 x 153	1
-550-112-0	1.4	220 x 74 x 153	1
-750-112-0	1.4	220 x 74 x 153	1
-111-112-0	1.8	220 x 74 x 153	1

Frequency inverters SK 5xxE ...	Weight [kg]	(Overall) dimensions H x W x D [mm]	Size
-250-323-A	1.6	220 x 74 x 153	1
-370-323-A	1.6	220 x 74 x 153	1
-550-323-A	1.6	220 x 74 x 153	1
-750-323-A	1.6	220 x 74 x 153	1
-111-323-A	2.0	260 x 74 x 153	2
-151-323-A	2.0	260 x 74 x 153	2
-221-323-A	2.0	260 x 74 x 153	2
-301-323-A	2.7	275 x 98 x 181	3
-401-323-A	2.7	275 x 98 x 181	3
-551-323-A	8.0	357 x 162 x 224	5
-751-323-A	8.0	357 x 162 x 224	5
-112-323-A	10.3	397 x 180 x 234	6
-152-323-A	15.0	485 x 210 x 236	7
-182-323-A	15.0	485 x 210 x 236	7

# NORDAC *PRO* SK 500E frequency inverter

## 3~ 380 ... 480 V

<b>Output frequency</b>	0.0 ... 400.0 Hz	<b>Protection class</b>	IP20
<b>Pulse frequency</b>	3.0 ... 16.0 kHz	<b>Regulation and control</b>	Sensorless current vector control (ISD), linear V/f characteristic curve
<b>Typical overload capacity</b>	150 % for 60 s, 200 % for 3.5 s	<b>Motor temperature monitoring</b>	I <sup>2</sup> t Motor PTC / bi-metal switch
<b>Frequency inverter efficiency</b>	IE2 Size 1 -4 approx. 95 % Size 5 -7 approx. 97 % Size 8 -11 approx. 98 %	<b>Leakage current</b>	<30 mA, may be considerably less depending on the size and configuration of the frequency inverter (refer to the manual for details)
<b>Ambient temperature</b>	0 °C ... +40 °C (S1) 0 °C ... +50 °C (S3, -70 % ED)		

Frequency inverters SK 5xxE ...	Nominal motor power		Nominal output current rms [A]	Mains voltage	Output voltage
	400 V [kW]	480 V [hp]			
-550-340-A	0.55	3/4	1.7	3~ 380 ... 480 V, -20 % / +10 %, 47 ... 63 Hz	3~ 0 up to mains voltage
-750-340-A	0.75	1	2.3		
-111-340-A	1.1	1 1/2	3.1		
-151-340-A	1.5	2	4.0		
-221-340-A	2.2	3	5.5		
-301-340-A	3.0	4	7.5		
-401-340-A	4.0	5	9.5		
-551-340-A	5.5	7 1/2	12.5		
-751-340-A	7.5	10	16.0		
-112-340-A	11.0	15	24.0		
-152-340-A	15.0	20	31.0		
-182-340-A	18.5	25	38.0		
-222-340-A	22.0	30	46.0		
-302-340-A	30.0	40	60.0		
-372-340-A	37.0	50	75.0		
-452-340-A	45.0	60	90.0		
-552-340-A	55.0	75	110.0		
-752-340-A	75.0	100	150.0		
-902-340-A	90.0	125	180.0		
-113-340-A	110	150	220.0		
-133-340-A	132	180	260.0		
-163-340-A	160	220	320.0		

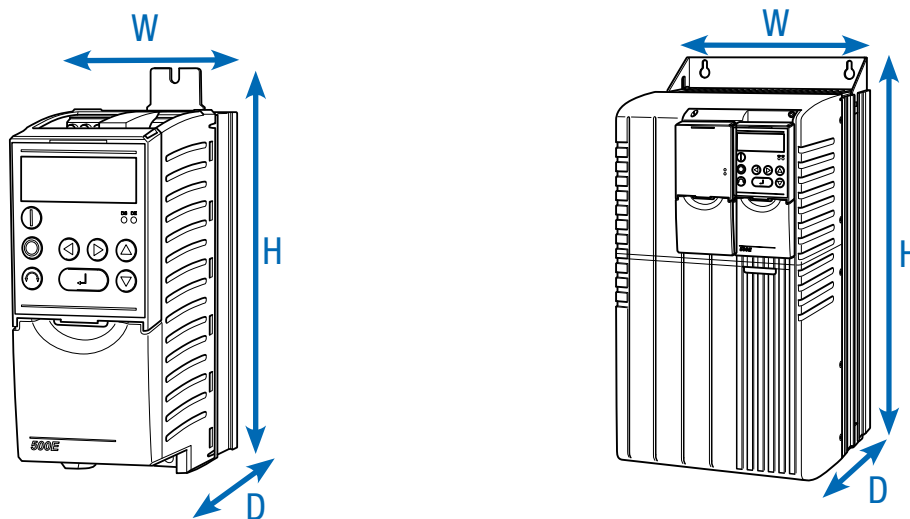

Frequency inverters SK 5xxE ...	Weight [kg]	(Overall) dimensions H x W x D [mm]	Size
-550-340-A	1.4	220 x 74 x 153	1
-750-340-A	1.4	220 x 74 x 153	1
-111-340-A	1.8	260 x 74 x 153	2
-151-340-A	1.8	260 x 74 x 153	2
-221-340-A	1.8	260 x 74 x 153	2
-301-340-A	2.7	275 x 98 x 181	3
-401-340-A	2.7	275 x 98 x 181	3
-551-340-A	3.1	320 x 98 x 181	4
-751-340-A	3.1	320 x 98 x 181	4
-112-340-A	8.0	357 x 162 x 224	5
-152-340-A	8.0	357 x 162 x 224	5
-182-340-A	10.3	397 x 180 x 234	6
-222-340-A	10.3	397 x 180 x 234	6
-302-340-A	16.0	485 x 210 x 236	7
-372-340-A	16.0	485 x 210 x 236	7
-452-340-A	20.0	598 x 265 x 286	8
-552-340-A	20.0	598 x 265 x 286	8
-752-340-A	25.0	636 x 265 x 286	9
-902-340-A	25.0	636 x 265 x 286	9
-113-340-A	46.0	720 x 395 x 292	10
-133-340-A	49.0	720 x 395 x 292	10
-163-340-A	52.0	799 x 395 x 292	11

# Interfaces for operation, parameterisation and communication

## Operation and parameterisation





Optional modules with up to 14 languages for displaying status and operational indicators, parameterisation and operation of the frequency inverter. In addition to

variants for direct mounting on the device or installation in a control cabinet door, handheld versions are also available. See also Accessories starting on page 165

Type Designation Material No.	Description	Remarks
 PotentiometerBox SK TU3-POT 275 900 110	Suitable for control, potentiometer 0 ... 100% .	Installation in the SK TU3 slot on the FI. <sup>1</sup>
 ParameterBox SK TU3-PAR 275 900 100	Suitable for control and parameterisation, LCD screen (illuminated), plain text display in 14 languages, memory for 5 device data sets, convenient control keypad.	Installation in the SK TU3 slot on the frequency inverter. <sup>1</sup>
 ControlBox SK TU3-CTR 275 900 090	Suitable for control and parameterisation, 4-digit, 7-segment display, convenient control keypad.	Installation in the SK TU3 slot on the FI. <sup>1</sup>
 SimpleBox SK CSX-0 275 900 095	Suitable for control and parameterisation, 4-digit, 7-segment display, direct control of a device, one-button operation.	The module is connected to the RJ 12 interface of the frequency inverter and does not occupy the option slot for SK TU3 modules. Simultaneous control of a bus interface is therefore possible. Mounted on the frequency inverter
 ParameterBox SK PAR-5H 275 281 614	Control and parameterisation, LCD (illuminated), plain text display in 14 languages, direct control of up to five devices, memory for five device data sets, convenient control keypad, communication via RS-485, including 1.5 m connection cable. Handheld, suitable for installation in a control cabinet door. IP54	Connection for data exchange with NORDCON <i>STUDIO</i> to a PC (USB 2.0), (standard "USB-C" connection cable required, e.g. material number: 275 292 100) Power supply, e.g. directly via frequency inverter or PC
 SimpleControlBox SK CSX-3E 275 281 413	Suitable for control and parameterisation, 4-digit, 7-segment display, direct control of a frequency inverter, convenient control keypad.	Electrical data: 4.5 ... 30 V DC / 1.3 W, Supply e. g. directly via the frequency inverter. Control cabinet installation
 Control and parameterisation software NORDCON	Software for control and parameterisation as well as support for commissioning and fault analysis of NORD electronic drive technology. Parameter names in 14 languages	Free download: <a href="http://www.nord.com">www.nord.com</a>
 Bluetooth stick NORDAC ACCESS BT SK TIE5-BT-STICK 275 900 120	Interface for wireless connection to a mobile terminal device (e.g. tablet or smartphone) via Bluetooth. The NORDCON APP, the NORDCON software for mobile terminal devices, enables smart operation and parameterisation as well as commissioning assistance and fault analysis of NORD electronic drive technology.	Available free of charge for Android and iOS 

<sup>1</sup> Cannot be combined with other SK TU3 modules as only one slot is available on the device..

# Industrial Ethernet, Field bus and IO extensions

Variant		Designation Material No.	Description Connection	Remarks
EtherCAT®		SK TU3-ECT 275 900 180	Ethernet-based bus interface Type EtherCAT®. 2 x RJ45	Baud rate: maximum 100 MBaud 24 V DC connection: via terminal Usable as a gateway to control up to a total of four frequency inverters.
EtherNet/IP®		SK TU3-EIP 275 900 150	Ethernet-based bus interface Type EtherNet / IP® 2 x RJ45	Baud rate: maximum 100 MBaud 24 V DC connection: via terminal Usable as a gateway to control up to a total of four frequency inverters.
POWERLINK		SK TU3-POL 275 900 140	Ethernet-based bus interface Type POWERLINK 2 x RJ45	Baud rate: maximum 100 MBaud 24 V DC connection: via terminal Usable as a gateway to control up to a total of four frequency inverters.
PROFINET IO®		SK TU3-PNT 275 900 190	Ethernet-based bus interface Type PROFINET IO®. 2 x RJ45	Baud rate: maximum 100 MBaud 24 V DC connection: via terminal Usable as a gateway to control up to a total of four frequency inverters.

# Line filter

## Improvement of EMC

### General

Line filters are used to reduce the emission of electromagnetic interference. SK 500E series frequency inverters are equipped with an integrated class C2 (max. 20 m shielded motor cable) or class C1 (size 1-4, max. 5 m shielded motor cable) line filter. Various adaptive line filters are available for longer cable lengths or to improve interference suppression.

### Chassis line filter, SK HLD

The line filter meets protection class IP20 and enables interference suppression Class C1 with max. 25 m shielded motor cable and Class C2 with max. 50 m cable.

The line filters are installed separately from the frequency inverter.

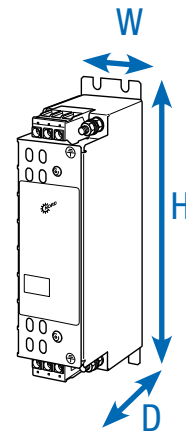

	Frequency inverters SK 5xxE ...	Line filter type Material No.	Continuous current [A]	Leakage current <sup>1</sup> [mA]	(Overall) dimensions H x W x D [mm]
3~ 230 V	0.25 ... 1.1 kW	SK HLD 110-500/8 278 272 008	8.0	20 / 190	190 x 45 x 75
	1.5 ... 2.2 kW	SK HLD 110-500/16 278 272 016	16.0	21 / 205	250 x 45 x 75
	3.0 ... 5.5 kW	SK HLD 110-500/30 278 272 030	30.0	29 / 280	270 x 55 x 95
	7.5 kW	SK HLD 110-500/42 278 272 042	42.0	30 / 290	310 x 55 x 95
	11 kW	SK HLD 110-500/75 278 272 075	75.0	22 / 210	310 x 85 x 135
	15 ... 18.5 kW	SK HLD 110-500/100 278 272 100	100.0	30 / 290	325 x 95 x 150
3~ 400 V	0.55 ... 2.2 kW	SK HLD 110-500/8 278 272 008	8.0	20 / 190	190 x 45 x 75
	3.0 ... 5.5 kW	SK HLD 110-500/16 278 272 016	16.0	21 / 205	250 x 45 x 75
	7.5 kW	SK HLD 110-500/30 278 272 030	30.0	29 / 280	270 x 55 x 95
	11 kW	SK HLD 110-500/42 278 272 042	42.0	30 / 290	310 x 55 x 95
	15 ... 18.5 kW	SK HLD 110-500/55 278 272 055	55.0	30 / 290	255 x 85 x 95
	22 kW	SK HLD 110-500/75 278 272 075	75.0	22 / 210	310 x 85 x 135
	30 kW	SK HLD 110-500/100 278 272 100	100.0	30 / 290	325 x 95 x 150
	37... 45 kW	SK HLD 110-500/130 278 272 130	130.0	22 / 210	325 x 95 x 150
	55 kW	SK HLD 110-500/180 278 272 180	180.0	31 / 300	440 x 130 x 181
	75 ... 90 kW	SK HLD 110-500/250 278 272 250	250.0	37 / 355	525 x 155 x 220

<sup>1</sup> Leakage current 1st value: rated for the maximum permissible input voltage fluctuation according to IEC 38 + 10%

Leakage current 2nd value: calculated at maximum input voltage and failure of 2 phases (typically at 50 Hz)



## Bottom-mounted line filter, combination filter SK NHD

The line filter meets protection class IP20 and is available for frequency inverter powers of 7.5 kW (400 V). The line filter can be mounted flat underneath the frequency inverter. This reduces the space requirement. These combination filters combine the advantages of a line filter and a line choke in a single housing and enable class C1 interference suppression with max. 50 m shielded motor cable and class C2 with max. 100 m cable.

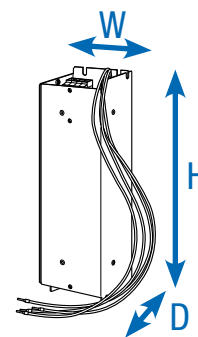

	Frequency inverters SK 5xxE ...	Line filter type Material No.	Continuous current [A]	Inductance [mH]	Leakage current <sup>1</sup> [mA]	(Overall) dimensions H x W x D [mm]
3~ 230 V	0.25 ... 0.75 kW	SK NHD-480/6-F 278 273 006	5.5	3 x 6.4	7.7 / 74.4	290 x 88 x 74
	1.1 ... 2.2 kW	SK NHD-480/10-F 278 273 010	9.5	3 x 3.7	15.0 / 144.0	305 x 115 x 98
	3.0 ... 4.0 kW	SK NHD-480/16-F 278 273 016	16.0	3 x 2.2	21.5 / 206.5	350 x 140 x 98
3~ 400 V	0.55 ... 0.75 kW	SK NHD-480/3-F 278 273 003	2.3	3 x 15.3	4.3 / 40.0	250 x 75 x 60
	1.1 ... 2.2 kW	SK NHD-480/6-F 278 273 006	5.5	3 x 6.4	7.7 / 74.4	290 x 88 x 74
	3.0 ... 4.0 kW	SK NHD-480/10-F 278 273 010	9.5	3 x 3.7	15.0 / 144.0	305 x 115 x 98
	5.5 ... 7.5 kW	SK NHD-480/16-F 278 273 016	16.0	3 x 2.2	21.5 / 206.5	350 x 140 x 98

<sup>1</sup> Leakage current 1st value: rated for the maximum permissible input voltage fluctuation according to IEC 38 + 10%

Leakage current 2nd value: calculated at maximum input voltage and failure of 2 phases (typically at 50 Hz)

# Line filter

## Improvement of EMC

### Bottom-mounted line filter, SK LF2

The line filter meets protection class IP00 and is available for frequency inverter powers of 37 kW (400 V). The line filter can be mounted flat underneath the frequency inverter.

This reduces the space requirement. These line filters enable class C1 interference suppression with max. 50 m shielded motor cable and class C2 with max. 100 m cable.

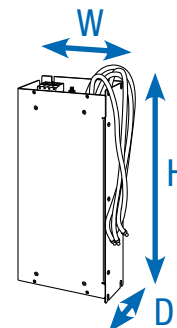

	Frequency inverters SK 5xxE ...	Line filter type Material No.	Continuous current [A]	Leakage current <sup>1</sup> [mA]	(Overall) dimensions H x W x D [mm]
3~ 230 V	5.5 ... 7.5 kW	SK LF2-480/45-F 278 273 045	45.0	12 / 120	388 x 164 x 75
	11.0 kW	SK LF2-480/66-F 278 273 066	66.0	12 / 120	428 x 182 x 75
	15 ... 18.5 kW	SK LF2-480/105-F 278 273 105	105.0	22 / 210	527 x 210 x 95
3~ 400 V	0.55 ... 0.75 kW	SK LF2-480/2-F 278 273 002	2.3	6,4 / 61,5	250 x 75 x 48
	1.1 ... 2.2 kW	SK LF2-480/5-F 278 273 005	5.5	7.7 / 74.3	290 x 88 x 48
	3.0 ... 4.0 kW	SK LF2-480/9-F 278 273 009	9.5	19.5 / 187	305 x 115 x 54
	5.5 ... 7.5 kW	SK LF2-480/15-F 278 273 015	16.0	20.2 / 193	350 x 115 x 54
	11.0 ... 15.0 kW	SK LF2-480/45-F 278 273 045	45.0	12 / 120	388 x 164 x 75
	18.5 ... 22.0 kW	SK LF2-480/66-F 278 273 066	66.0	12 / 120	428 x 182 x 75
	30.0 ... 37.0 kW	SK LF2-480/105-F 278 273 105	105.0	22 / 210	527 x 210 x 95

<sup>1</sup>leakage current 1st value: rated for the maximum permissible input voltage fluctuation according to IEC 38 + 10%

Leakage current 2nd value: calculated at maximum input voltage and failure of 2 phases (typically at 50 Hz)

# Mains chokes

## Reduction of mains feedback

### General

It may be necessary for some drive systems to use mains chokes to reduce dangerous mains current peaks. With their use, external mains feedback effects are considerably reduced and the proportion of current harmonics is reduced to a minimum. The input current is reduced to approximately the value of the output current.

It is recommended that a mains choke be used at all times for a frequency inverter capacity of 45 kW and above. This will have an additional positive effect on device protection and EMC characteristics. All chokes have protection class IP00 and are UL-recognised.

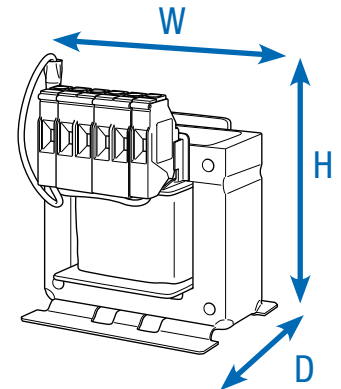

	Frequency inverters SK 5xxE ...	Choke type Material No.	Continuous current [A]	Inductance [mH]	(Overall) dimensions H x W x D [mm]
1 ~ 230V	0.25 ... 0.75 kW	SK CI1-230/8-C 278 999 030	8.0	2 x 1.0	89 x 65 x 78
	1.1 ... 2.2 kW	SK CI1-230/20-C 278 999 040	20.0	2 x 0.4	106 x 90 x 96
3 ~ 230V	0.25 ... 0.75 kW	SK CI1-480/6-C 276 993 006	6.0	3 x 4.88	117 x 96 x 60
	1.1 ... 1.5 kW	SK CI1-480/11-C 276 993 011	11.0	3 x 2.93	140 x 120 x 85
	2.2 ... 3.0 kW	SK CI1-480/20-C 276 993 020	20.0	3 x 1.47	177 x 155 x 110
	4.0 ... 7.5 kW	SK CI1-480/40-C 276 993 040	40.0	3 x 0.73	172 x 155 x 115
	11.0 ... 15.0 kW	SK CI1-480/70-C 276 993 070	70.0	3 x 0.47	220 x 185 x 122
	18.5 kW	SK CI1-480/100-C 276 993 100	100.0	3 x 0.29	263 x 240 x 148
3 ~ 400V	0.55 ... 2.2 kW	SK CI1-480/6-C 276 993 006	6.0	3 x 4.88	117 x 96 x 60
	3.0 ... 4.0 kW	SK CI1-480/11-C 276 993 011	11.0	3 x 2.93	140 x 120 x 85
	5.5 ... 7.5 kW	SK CI1-480/20-C 276 993 020	20.0	3 x 1.47	177 x 155 x 110
	11.0 ... 15.0 kW	SK CI1-480/40-C 276 993 040	40.0	3 x 0.73	172 x 155 x 115
	18.5 ... 30.0 kW	SK CI1-480/70-C 276 993 070	70.0	3 x 0.47	220 x 185 x 122
	37.0 ... 45.0kW	SK CI1-480/100-C 276 993 100	100.0	3 x 0.29	263 x 240 x 148
	55.0 ... 75.0 kW	SK CI1-480/160-C 276 993 160	160.0	3 x 0.18	268 x 352 x 140
	90.0 kW	SK CI1-480/280-C 276 993 280	280.0	3 x 0.10	268 x 352 x 169
	110 ... 132 kW	SK CI1-480/350-C 276 993 350	350.0	3 x 0.08	268 x 352 x 169
	160 kW	nicht verfügbar			

# Link circuit choke

## Reduction of mains feedback

### Link circuit choke SK DCL

Similar to a mains choke, reduces the network loads of a frequency inverter that are inherent to its functional principle. It is connected to easily accessible contacts in the frequency inverter's intermediate circuit and is available for 45 kW and above. All chokes have protection class IP00 and are UL-recognised.

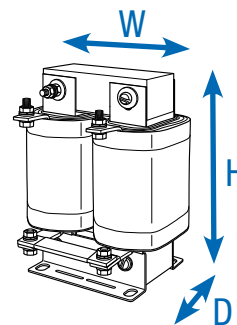

Frequency inverter SK 5xxE ...	Choke type Material No.	Continuous current [A]	Inductance [mH]	(Overall) dimensions H x W x D [mm]
45.0 ... 55.0 kW	SK DCL-950/120-C 276 997 120	120	0.50	230 x 148 x 147
75.0 ... 90.0 kW	SK DCL-950/200-C 276 997 200	200	0.30	260 x 170 x 153
110 kW	SK DCL-950/260-C 276 997 260	260	0.25	284 x 180 x 174
132 kW	SK DCL-950/320-C 276 997 320	320	0.20	282 x 180 x 189
160 kW	SK DCL-950/380-C 276 997 380	200	0.17	282 x 180 x 189

# Motor chokes

## Compensation of cable capacitances

### General

Long motor cable lengths (cable capacity) often require the use of additional motor chokes (output chokes) on the frequency inverter output.

In addition, the use of motor chokes has a positive effect on device protection and EMC characteristics.

The specified motor chokes are rated for a pulse frequency of 3 to 6 kHz and an output frequency of 0 to 120 Hz. All chokes have protection class IP00 and are UL-recognised.

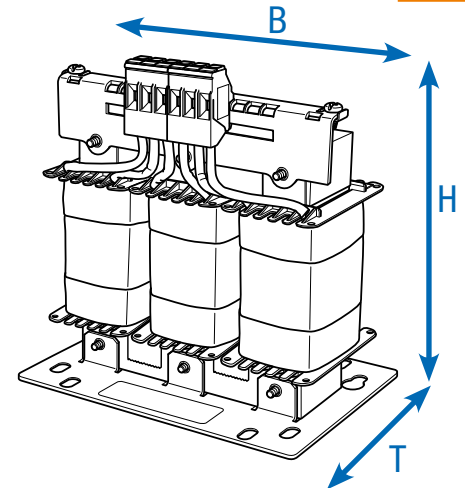

Frequency inverter SK 5xxE ...	Choke type Material No.	Continuous current [A]	Inductance [mH]	(Overall) dimensions H x W x D [mm]
3~ 230 V	0.25 ... 0.75 kW SK C01-460/4-C 276 996 004	4	3 x 3.5	140 x 120 x 104
	1.1 ... 1.5 kW SK C01-460/9-C 276 996 009	9	3 x 2.5	160 x 155 x 110
	2.2 ... 4.0 kW SK C01-460/17-C 276 996 017	17	3 x 1.2	201 x 185 x 102
	5.5 ... 7.5 kW SK C01-460/33-C 276 996 033	33	3 x 0.6	201 x 185 x 122
	11.0 ... 15.0 kW SK C01-480/60-C 276 992 060	60	3 x 0.33	210 x 185 x 112
	18.5 kW SK C01-460/90-C 276 996 090	90	3 x 0.22	325 x 352 x 144
3~ 400 V	0.55 ... 1.5 kW SK C01-460/4-C 276 996 004	4	3 x 3.5	140 x 120 x 104
	2.2 ... 4.0 kW SK C01-460/9-C 276 996 009	9	3 x 2.5	160 x 155 x 110
	5.5 ... 7.5 kW SK C01-460/17-C 276 996 017	17	3 x 1.2	201 x 185 x 102
	11.0 ... 15.0 kW SK C01-460/33-C 276 996 033	33	3 x 0.6	201 x 185 x 122
	18.5 ... 30 kW SK C01-480/60-C 276 992 060	60	3 x 0.33	210 x 185 x 112
	37.0 ... 45.0 kW SK C01-460/90-C 276 996 090	90	3 x 0.22	352 x 144 x 325
	55.0 ... 75.0 kW SK C01-460/170-C 276 996 170	170	3 x 0.13	320 x 412 x 200
	90.0 ... 110 kW SK C01-460/240-C 276 996 240	240	3 x 0.07	320 x 412 x 225
132 ... 160 kW SK C01-460/330-C 276 996 330	330	3 x 0.03	268 x 352 x 188	

# Braking resistors for dynamic drive characteristics

## Bottom-mounted braking resistors SK BR4

are available in four sizes for frequency inverter capacities of up to 7.5 kW (400 V). This brake resistor can be mounted flat or vertically, next to the frequency inverter. This reduces the space requirement.

The specified resistance values are electrically matched to standard applications.

All brake resistors have protection class IP40 and are UL-recognised.

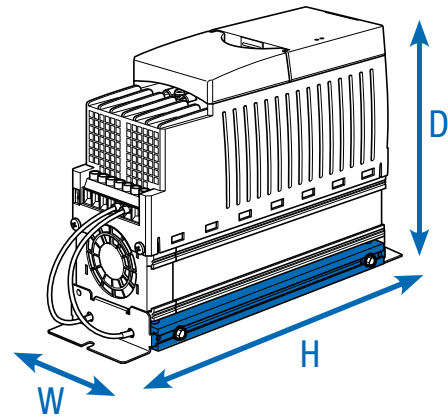

	Frequency inverter SK 5xxE ...	Resistor type Material No.	Resistance [Ω]	Continuous output [W]	Short-term power [kW] <sup>1</sup>	(Overall) dimensions L x W x D [mm]
230 V / 115 V	0.25 ... 0.37 kW	SK BR4-240/100 275 991 110	240	100	2.2	230 x 88 x 175
	0.55 ... 0.75 kW	SK BR4-150/100 275 991 115	150	100	2.2	230 x 88 x 175
	1.1 ... 2.2 kW	SK BR4-75/200 275 991 120	75	200	4.4	270 x 88 x 175
	3.0 ... 4.0 kW	SK BR4-35/400 275 991 140	35	400	8.8	285 x 98 x 239
400 V	0.55 ... 0.75 kW	SK BR4-400/100 275 991 210	400	100	2.2	230 x 88 x 175
	1.1 ... 2.2 kW	SK BR4-220/200 275 991 220	220	200	4.4	270 x 88 x 175
	3.0 ... 4.0 kW	SK BR4-100/400 275 991 240	100	400	8.8	285 x 98 x 239
	5.5 ... 7.5 kW	SK BR4-60/600 275 991 260	60	600	13.0	330 x 98 x 239

Temperature monitoring for SK BR4 resistors  
with installation close to the inverter  
275 991 100

Bimetallic switch  
as opener  
Nominal switching temperature: 180°C

Broad brake resistor + 10 mm  
(on one side)

Temperature monitoring for SK BR4 resistors  
with direct installation  
under the frequency inverter  
275 991 200

Bimetallic switch  
as opener  
Nominal switching temperature: 100°C

The dimensions apply to the  
frequency inverter,  
including the braking resistor

<sup>1</sup> Once within 120 s,  
for a maximum duration of 1.2 s



## Chassis braking resistors, SK BR2

The resistor elements are integrated into a housing cage and must be connected to the particular frequency inverter via a separate connecting cable. The brake resistors must be mounted horizontally (apart from SK BR2-xxx/400-C). A shielded cable which is as short as possible should be used for this purpose.

All brake resistors have protection class IP20 and are UL-recognised.

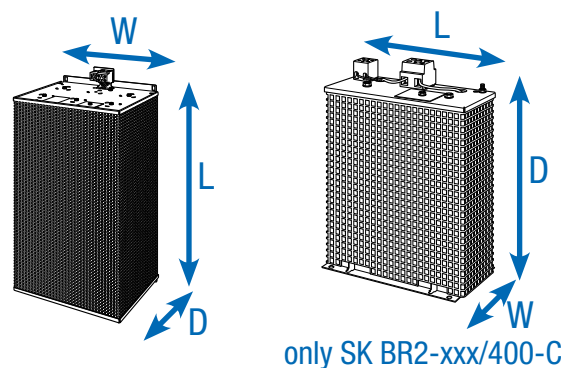

	Frequency inverter SK 5xxE ...	Resistor type Material No.	Resistance [Ω]	Continuous out- put [W]	Short-term power [kW] <sup>2</sup>	(Overall) dimensions L x W x D [mm]
230 V	3.0 ... 4.0 kW	SK BR2-35/400-C <sup>1</sup> 278 282 045	35	400	12	178 x 100 x 252
	5.5 ... 7.5 kW	SK BR2-22/600-C 278 282 065	22	600	18	385 x 92 x 120
	11.0 kW	SK BR2-12/1500-C 278 282 015	12	1500	45	585 x 185 x 120
	15.0 ... 18.5 kW	SK BR2-9/2200-C 278 282 122	9	2200	66	485 x 275 x 120
400 V	3.0 ... 4.0 kW	SK BR2-100/400-C <sup>1</sup> 278 282 040	100	400	12	178 x 100 x 252
	5.5 ... 7.5 kW	SK BR2-60/600-C 278 282 060	60	600	18	385 x 110 x 120
	11.0 ... 15.0 kW	SK BR2-30/1500-C 278 282 150	30	1500	45	585 x 185 x 120
	18.5 ... 22.0 kW	SK BR2-22/2200-C 278 282 220	22	2200	66	485 x 275 x 120
	30.0 ... 37.0 kW	SK BR2-12/4000-C 278 282 400	12	4000	120	585 x 266 x 210
	45.0 ... 55.0 kW	SK BR2-8/6000-C 278 282 600	8	6000	180	395 x 490 x 260
	75.0 ... 110 kW	SK BR2-6/7500-C 278 282 750	6	7500	225	595 x 490 x 260
	132 ... 160 kW	SK BR2-3/7500-C 278 282 753	3	7500	225	595 x 490 x 260
	132 ... 160 kW	SK BR2-3/17000-C 278 282 754	3	17 000	510	795 x 490 x 260

Temperature monitoring for SK BR2 resistors  
integrated (2 terminals 4 mm<sup>2</sup>)

Bimetallic switch as opener.  
Nominal switching temperature: 180°C.

<sup>1</sup> Type of assembly: vertical

<sup>2</sup> Once within 120 s,  
for a maximum duration of 1.2 s

# NORDAC *PRO* frequency inverters

## Accessories



### EMV-Kit

For EMC-compliant connection of shielded cables and to produce strain relief.

Size of frequency inverter	EMV-Kit	Material No.
Size 1 and size 2	SK EMC 2-1	275 999 011
Size 3 and size 4	SK EMC 2-2	275 999 021
Size 5	SK EMC 2-3	275 999 031
Size 6	SK EMC 2-4	275 999 041
Size 7	SK EMC 2-5	275 999 051
Size 8 and size 9	SK EMC 2-6	275 999 061
Size 10 and size 11	SK EMC 2-7	275 999 071



### Connection Kit HTL encoder WK 4/2/4\*680 OHM

For connection of an HTL encoder to the TTL encoder input of the frequency inverter, top-hat rail mounting.

Material No.: 278 910 340



### RJ45 WAGO connection module

For example to connect a CANopen® encoder to one of the two RJ45 connection sockets of the frequency inverter.  
Material No.: 278 910 300



### Signal converter +/- 10 V

For connection of a bipolar analogue signal to the unipolar analogue input of a frequency inverter (up to size 4), top-hat rail mounting.  
Material No.: 278 910 320



### IO expansion SK EBIOE-2

The generous number of standard inputs and outputs on the device can be supplemented using an extension provided for top-hat rail mounting.  
Material No.: 275 900 210  
Available for SK 540E and higher



### Electronic brake rectifier SK EBGR-1

For direct control and supply of an electromagnetic holding brake.  
Material No.: 19 140 990



### Adapter module V/I CONVERTER 10 V/20 mA

The module serves the conversion of analogue (0–10 V) signals into equivalent current signals (0–20 mA).  
Part no.: 278910315











### Adapter module level adapter HTL – RS422



The module serves the conversion of HTL or TTL signals into complementary signals with RS422 levels, top-hat rail mounting  
Part no.: 278910360



# Operation and parameterisation

## Control and parameterisation units /software

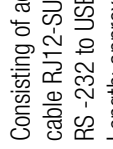
Designation Material No.	Description	Remarks
 <p>ParameterBox SK PAR-5H 275281614</p>	Control and parameterisation, LCD (illuminated), plain text display in 14 languages, direct control of up to five devices, memory for five device data sets, convenient control keypad, communication via RS-485, including 1.5 m connection cable. Handheld, suitable for installation in a control cabinet door. IP54	Connection for data exchange with <i>NORDCON STUDIO</i> to a PC (USB 2.0), (standard "USB-C" connection cable required, e.g. material number: 275292100) Power supply, e.g. directly via frequency inverter or PC
 <p>SimpleControlBox SK CSX-3H 275281013</p>	Control and parameterisation, 4-digit, 7-segment display, direct control of a device, convenient control keypad, including 2 m connection cable Handheld, IP54	Electrical data: 4.5 ... 30 V DC / 1.3 W, supply e. g. directly via the frequency inverter
 <p>SimpleControlBox SK CSX-3E 275281413</p>	Suitable for control and parameterisation, 4-digit, 7-segment display, direct control of a device, convenient control keypad, for installation in control cabinet doors.	Electrical data: 4.5 ... 30 V DC / 1.3 W, supply e. g. directly via the frequency inverter. Control cabinet installation
 <p>Control box SK POT1-1 278910120</p>	Potentiometer 0 ... 100% (0 ... 10 V), switch Left/AUS/Right, including 3 m connection cable. Handheld, wall mounting, IP66	
 <p>Control box SK POT1-2 278910140</p>	Suitable for control, potentiometer 0 ... 100 % (0 ... 10 V), switch Left/AUS/Right, including 20 m connection cable. Handheld, wall mounting, IP66	
 <p>SimpleSetpointBox SK SXX-3A 275281513</p>	Suitable for control and parameterisation, 4-digit, 7-segment display, direct control of a device, 3 operating modes, convenient control keypad. Handheld, wall mounting, IP54	Electrical data: 19.2 ... 28.8 V DC, 35 mA, supply e.g. directly via the frequency inverter, communication via RS-485 or IO link
 <p>SK TIE4-SSX-3A- 275274910</p>	Adapter for fitting the SK SXX-3A to the <i>NORDAC FLEX</i>	
 <p>Programming adapter SK EPG-3H 275281026</p>	Suitable for parameterisation of the external EEPROM (memory module) of an SK 2xxE, independent of the presence of a frequency inverter. Handheld, IP20	

Designation Material No.	Description	Remarks
 <p>Adapter cable RJ12-SUB-D9 278 910 240</p>	<p>To connect the frequency inverter to the serial interface of a PC via SUB-D9</p>	<p>Length: approx. 3 m</p>
<p>Connection set SK TIE4-RS232-USB 275 274 604</p> 	<p>To connect the frequency inverter to the serial interface of a PC via USB 2.0</p>	<p>Consisting of adapter cable RJ12-SUB-D9 and RS-232 to USB inverter Length: approx. 3 m + 0.5 m</p>
<p>Control and parameterisation software NORDCON</p> 	<p>Software for control and parameterisation as well as commissioning assistance and fault analysis of NORD electronic drive technology. Parameter names in 14 languages</p>	<p>Free download: <a href="http://www.nord.com">www.nord.com</a></p>
<p>NORDAC ACCESS BT Bluetooth-Stick SK TIE5-BT-STICK 275 900 120</p> 	<p>Interface for wireless connection to a mobile terminal device (e.g. tablet or smartphone) via Bluetooth. With the aid of the NORDCON APP, the NORDCON software for mobile terminal devices, enables smart operation and parameterisation as well as commissioning assistance and fault analysis of NORD electronic drive technology.</p>	<p>NORDCON APP available free of charge for Android and iOS</p>

**Headquarters:**

Getriebebau NORD GmbH & Co. KG

Getriebebau-Nord-Str. 1

22941 Bargteheide, Deutschland

T: +49 (0) 45 32 / 289 - 0

F: +49 (0) 45 32 / 289 - 22 53

[info@nord.com](mailto:info@nord.com)