

Intelligent Drivesystems, Worldwide Services

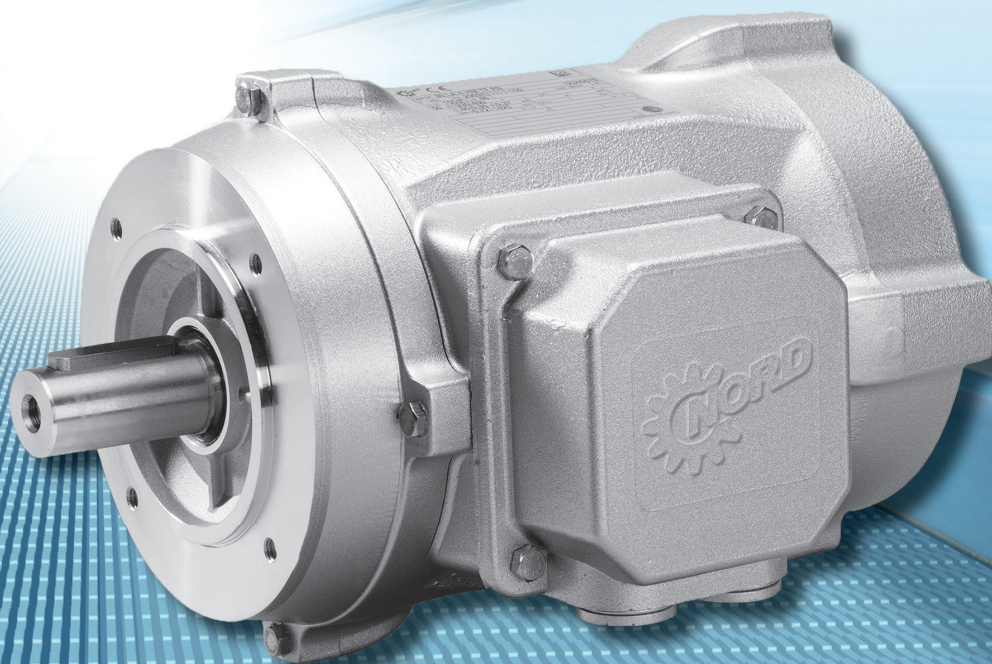

EN

**M7010**

**Motors with smooth surface**

Smooth motors type HM

Smooth motors type HMT

  
**DRIVESYSTEMS**

# Contents

---

<b>INTRODUCTION</b> .....	A 2
<b>NOMENCLATURE</b> .....	A 3
<b>OPTIONS</b> .....	A 4
<b>EXTENDED OPERATION RANGE AND INTERMITTENT OPERATION S3</b> .....	A 6
<b>MOTOR DATA AND DIMENSIONED DRAWINGS</b> .....	B 2



**DRIVESYSTEMS**

[www.nord.com](http://www.nord.com)



## Headquarters and Technology Centre

- in Bargteheide, close to Hamburg

### Mechanical products

Gear units

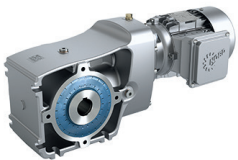

### Electrical products

Motors



### Electronic products

Inverters, motor starters and distribution systems

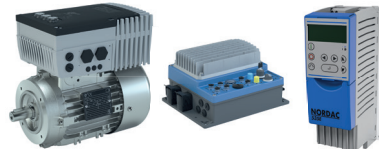

## Innovative drive solutions

- for more than 100 branches of industrial



Gear unit production



Motor production



Inverter production

## 7 state-of-the-art production plants

- produce gear units, motors and inverters also for complete drive solutions from a single source



## Subsidiaries and sales partners in 98 countries on 5 continents

- provide local stocks
- assembly and production centres
- technical support
- customer service

The above map image is for information purpose and may not have been prepared or be suitable for legal purpose and we do not own any responsibility for correctness or authenticity of the same.



## More than 4.900 employees throughout the world

- create customer oriented solutions

# NORD smooth surface motors



NORD DRIVESYSTEMS builds motors both with and without brakes for the international market.

Our own motor production facilities guarantee that NORD is independent from supply bottlenecks, ensuring short delivery times.

This is a decisive benefit for our customers.

The use of NORD energy-saving three-phase motors with considerably higher efficiencies allows you to reduce operating costs.

This catalogue presents unventilated and ventilated NORD motors with smooth surfaces. Smooth surfaces are important, for example, where motors must be simply and thoroughly cleaned.

## Advantages

- Smooth surfaces, especially suitable for applications in the food and beverage industry.
- A wide choice of motor sizes 71, 80, 90, 100 for the major applications.
- The motors are based on the NORD modular construction system and therefore offer maximum flexibility.

## Features

- Aluminium housing (smooth surface).
- Easy to clean thanks to smooth surfaces (Washdown = water always runs off).
- Perfectly suited for NORD smooth surface gear units as complete gearmotor assemblies.



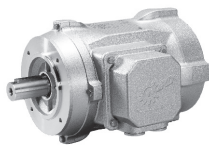

## Motor power labelling

Shaft height 71, 80, 90, 100

Power code S, L, T

Efficiency class H/P = premium T 1,3,5 = IE4 IE3 unventilated IE2 ventilated

Number of poles 4-pole

Motor type Labelling only for motors with special characteristics  
HM Smooth motors

Variant unventilated (Standard)  
L/H ventilated

Option ⇒  A4-5

### Example

100 L H / 4 HM TF = Shaft height 100 Power code L Efficiency class H No. of poles 4 Motor type HM Option TF

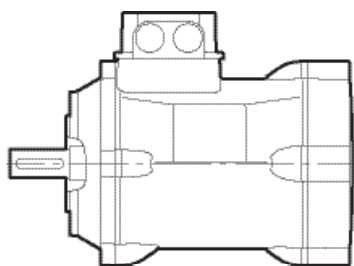

### Standard

Smooth motor, unventilated

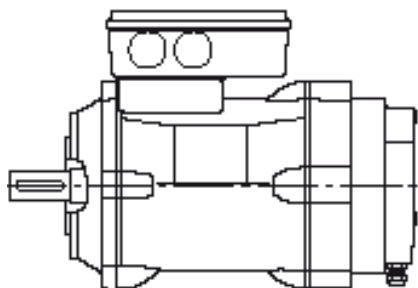

### Standard

Smooth motor with brake, unventilated



NORD smooth surface motors always comply with protection class IP66 and can be combined with every gear unit type.

The tables on pages ⇒  A6-A7 help you dimensioning your application, especially in intermittent operation.

# Options

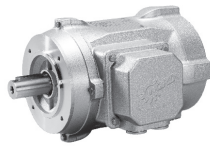

		Smooth motor						
		unventilated		unventilated		ventilated	unventilated	
		S / L					T	
		Standard HM		Standard HM		HM <sup>5)</sup>	PMSM HM	PMSM HMT
Abbreviations	Meaning							
IP66 BRE ...+ <sup>1)</sup>	Brake / braking torque + sub-option			x <sup>5)</sup>		x	x	x
IR	Current relay			x <sup>5)</sup>		x		
FHL	Lockable manual release			-		x		
HL	Manual brake release			x <sup>5)</sup>		x		
MIK	Micro switch			x <sup>5)</sup>		x		
BSH	Standstill heater / Brake			x <sup>5)</sup>		x		
NRB 1	Noise-reduced brake			-		-		
NRB 2	Noise-reduced brake			x <sup>5)</sup>		x		
IP69K	Protection class	x		x		x	x	x
TF	Thermistor, PTC resistor	x		x		x	x	x
TW	Thermostat, bimetallic switch	x		x		x	x	x
SH <sup>3)</sup>	Standstill heating	x		x		x	x	x
WE +	2. Shaft end			-		x		
HR	Hand wheel			-		x		
RD	Protective shield			-		x		
RDT	Protective shield, textile fan cowl			-		x		
RDD	Double fan-cowl			-		x		
KB	closeable condensation hole	x		x		x	x	x
KKV	Terminal box, encapsulated	x		x		x	x	x
MS	Plug-on motor coupling			x		x		
F	External fan			-		x		
IG1 (IG11, 12)	Pulsed incremental encoder 1024			-		x		
IG2 (IG21, 22)	Pulsed incremental encoder 2048			-		x		
IG4 (IG41, 42)	Pulsed incremental encoder 4096			-		x		
IG.K	Encoder with terminal box			-		x		

1) it is quick-switching rectifier to use

2) integrated brake ⇒ B7

3) Brake terminal box

5) not for size 71

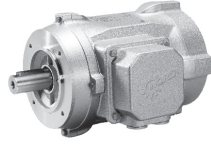

## Brake - attached brake IP66 (BRE)

By default, a closed brake is directly screwed to the B-bearing cover of the motor;  
E.g.: 80 LH/4 HM BRE5

## Current measuring relay (IR)

Generator operation is excluded after the motor was switched off;  
E.g.: 80 LH/4 HM BRE5 IR

## Micro switch (MIK)

Brake with electronic release monitor;  
E.g.: 80 LH/4 HM BRE5 MIK

## Standstill heater / brake (BSH)

To prevent the condensation of moisture and freezing of the brake, a the brake with standstill heater can be implemented;  
E.g.: 80 LH/4 HM BSH

## IP69K

Protection against the ingress of dust (IP6\_) and  
Protection against the penetration of water, even with high pressure or steam jet cleaning (IP\_9K)

## Thermal motor protection

NORD can supply two heat protection components.

- TF = Thermistor temperature sensor (series)
- TW = Bimetal temperature sensor (for an extra charge)

These are used to directly monitor the temperature of the windings with full utilisation of the motor power;  
E.g.: 80 LH/4 HM TF

## Standstill heating (SH)

A standstill heater must be used in case of severe temperature fluctuations, high humidity or extreme climatic conditions. This prevents condensation inside the motor;  
E.g.: 100 LH/4 HM SH

## 2. shaft end (WE)

Motors with a second shaft end on the B side;  
E.g.: 100 LH/4 HM L/H WE

## Handwheel (HR)

Motors with a handwheel mounted on the rear shaft end of the shaft;  
E.g.: 90 SH/4 HM L/H HR

## Protective cover (RD)

Protection against rain and entry of foreign bodies for vertical installation with the shaft pointing downwards;  
E.g.: 100 LH/4 HM L/H RD (⇒  B9, B11)

## Protective cover, textile fan cowl (RDT)

These motors have a fan cowl which is specially designed for use in the field of textiles. The lack of a normal ventilation grille prevents the build-up of flakes and fluff, which could impair the cooling of the motor;  
E.g.: 80 LH/4 HM L/H RDT (⇒  B9, B11)

## Double fan cowl (RDD)

Protection against rain and snow and entry of foreign bodies for vertical installation with the shaft pointing downwards. Suitable for water jets from all directions;  
E.g.: 90 SH/4 HM L/H RDD (⇒  B9, B11)

## Condensation drain hole (KB)

Depending on installation position, condensation drainage holes are drilled at the lowest position of the A or B bearing plate. These are closed with hex screws.  
⚠️The version must be stated!  
E.g.: 80 LH/4 HM KB

## Encapsulated terminal box (KKV)

Terminal box base encapsulated in direction of interior;  
E.g.: 80 LH/4 HM KKV

## Motor plug connectors (MS)

### Normal version

Terminal box at I, plug at II (to B-side, plug at I + III possible)  
The plug connector is mounted on the side of the terminal box. Housings with 2-clamp transverse locking are used. At the motor, there is a 10-pole pin version;  
E.g.: 80 LH/4 HM MS

## External fan (F)

Motor with separately controlled fan;  
E.g.: 90 SH/4 HM F

## Encoders

### Incremental encoder (IG)

Incremental encoders with various pulse numbers and interfaces are available. With “unventilated” motor variants, the encoder is protected underneath an aluminium cover.  
With the “ventilated” variants, the encoder is mounted under the fan cover.

### IG1K, IG2K or IG4K

With ventilated motors, an alternative connection in a separate terminal box is possible with the options IG1K, IG2K or IG4K (extra charge).

Quick-switching rectifier for installation in control cabinet

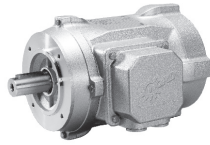

## Extended operation range and intermittent operation S3

In the S3 mode, the motors are not subject to the efficiency classification. The following data can be used for motor planning. The breakdown torque is always higher than the 1.6-fold operating torque. The maximum utilisation of the motors is in accordance with thermal class 155 (F).

The heating of unventilated motors greatly depends on the installation conditions. The maximum surface temperature is only insignificantly below the temperature of the windings.

400 V / 50 Hz 4 - pole		unventilated											
		S1			S3-60%			S3-40%			S3-25%		
Type		P <sub>N</sub> [kW]	I [A]	n [1/min]	P [kW]	I [A]	n [1/min]	P [kW]	I [A]	n [1/min]	P [kW]	I [A]	n [1/min]
80	LH/4	0,37	0,98	1425	0,5	1,2	1390	0,63	1,5	1340	0,7	1,67	1325
90	SH/4	0,55	1,27	1435	0,75	1,61	1405	0,9	1,9	1385	1,2	2,66	1305
100	SH/4	0,75	1,65	1450	1,1	2,25	1420	1,35	2,75	1395	1,5	3,0	1390
100	LH/4	1,1	2,4	1445	1,5	3,05	1425	1,8	3,6	1410	2,2	4,4	1380

460 V / 60 Hz 4 - pole		unventilated											
		S1			S3-60%			S3-40%			S3-25%		
Type		P <sub>N</sub> [kW]	I [A]	n [1/min]	P [kW]	I [A]	n [1/min]	P [kW]	I [A]	n [1/min]	P [kW]	I [A]	n [1/min]
80	LH/4	0,37	0,89	1735	0,5	1,05	1710	0,63	1,26	1680	0,7	1,38	1670
90	SH/4	0,55	1,14	1740	0,75	1,4	1720	0,9	1,62	1705	1,2	2,13	1665
100	SH/4	0,75	1,47	1755	1,1	1,95	1735	1,35	2,32	1715	1,5	2,55	1710
100	LH/4	1,1	2,14	1755	1,5	2,65	1735	1,8	3,1	1725	2,2	3,7	1710

Motors with increased power are electrically and mechanically modified compared with the energy-efficient motors.

400 V / 50 Hz 4 - pole		unventilated / Increased power											
		S1			S3-60%			S3-40%			S3-25%		
Type		P <sub>N</sub> [kW]	I [A]	n [1/min]	P [kW]	I [A]	n [1/min]	P [kW]	I [A]	n [1/min]	P [kW]	I [A]	n [1/min]
80	L/4	0,47	1,25	1420	0,6	1,46	1395	0,75	1,76	1360	0,9	2,15	1310
90	S/4	0,67	1,58	1435	0,9	1,94	1410	1,1	2,3	1390	1,4	3,0	1335
100	S/4	1,0	2,2	1445	1,3	2,67	1425	1,5	3,0	1415	1,7	3,4	1405
100	L/4	1,3	2,95	1450	1,75	3,62	1430	2,1	4,22	1415	2,5	5,0	1395

460 V / 60 Hz 4 - pole		unventilated / Increased power											
		S1			S3-60%			S3-40%			S3-25%		
Type		P <sub>N</sub> [kW]	I [A]	n [1/min]	P [kW]	I [A]	n [1/min]	P [kW]	I [A]	n [1/min]	P [kW]	I [A]	n [1/min]
80	L/4	0,53	1,2	1720	0,7	1,43	1690	0,85	1,68	1665	1,0	1,97	1630
90	S/4	0,77	1,53	1735	1,0	1,84	1715	1,25	2,22	1690	1,6	2,86	1640
100	S/4	1,15	2,13	1740	1,5	2,62	1725	1,8	3,08	1705	2,05	3,48	1695
100	L/4	1,45	2,8	1750	2,0	3,5	1725	2,4	4,1	1710	2,9	4,9	1690



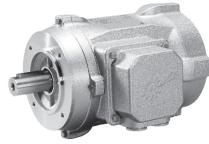

400 V / 50 Hz 4 - pole																
ventilated																
				S1				S3-60%			S3-40%			S3-25%		
Type				P <sub>N</sub>	P <sub>S1max</sub>	I	n	P	I	n	P	I	n	P	I	n
				[kW]	[kW]	[A]	[1/min]	[kW]	[A]	[1/min]	[kW]	[A]	[1/min]	[kW]	[A]	[1/min]
80	LH/4	HM	L/H	0,75	1,0	2,4	1360	1,1	2,63	1340	1,2	2,9	1310	1,3	3,17	1285
90	SH/4	HM	L/H	1,1	1,5	3,28	1380	1,65	3,6	1365	1,8	3,93	1345	2,0	4,42	1315
100	SH/4	HM	L/H	1,5	2,15	4,36	1400	2,35	4,77	1390	2,55	5,21	1375	2,85	5,94	1355
100	LH/4	HM	L/H	2,2	2,75	5,65	1415	3,0	6,11	1405	3,3	6,7	1390	3,75	7,67	1370

460 V / 60 Hz 4 - pole																
ventilated																
				S1				S3-60%			S3-40%			S3-25%		
Type				P <sub>N</sub>	P <sub>S1max</sub>	I	n	P	I	n	P	I	n	P	I	n
				[kW]	[kW]	[A]	[1/min]	[kW]	[A]	[1/min]	[kW]	[A]	[1/min]	[kW]	[A]	[1/min]
80	LH/4	HM	L/H	0,75	1,25	2,46	1640	1,35	2,67	1620	1,45	2,89	1600	1,55	3,11	1585
90	SH/4	HM	L/H	1,1	1,85	3,37	1665	2,0	3,63	1650	2,15	3,92	1635	2,35	4,31	1620
100	SH/4	HM	L/H	1,5	2,55	4,38	1695	2,8	4,82	1680	3,0	5,18	1675	3,4	6,0	1645
100	LH/4	HM	L/H	2,2	3,3	5,68	1705	3,65	6,25	1695	3,95	6,75	1685	4,45	7,66	1665

# Notes

---



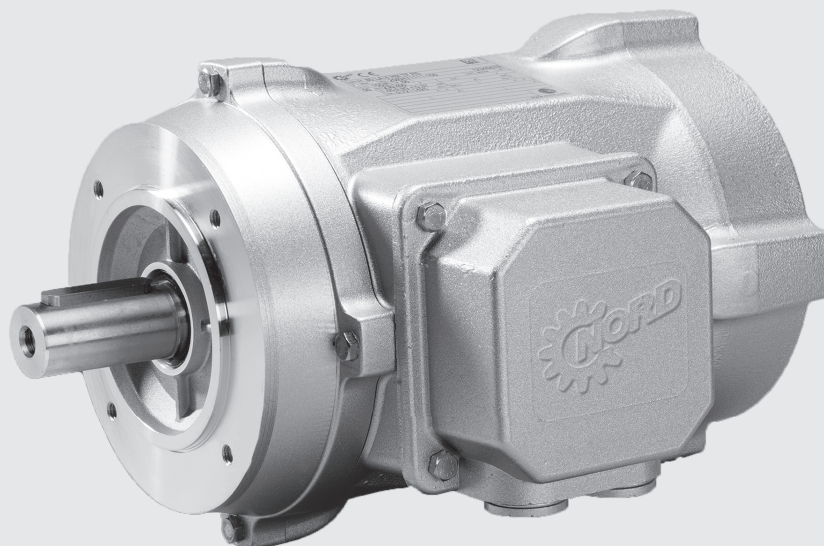

## MOTOR DATA

**Standard HM/HMT**  
unbelüftet

1500 1/min  
50 Hz

230/400 V / 400/690 V  
4 - polig

Type	S1	P <sub>N</sub> [kW]	I <sub>N</sub> [A]	I <sub>Δ</sub> [A]	cos φ	η	1200 P <sub>N</sub> [h]	340 P <sub>N</sub> [h]	440 P <sub>N</sub> [h]	M <sub>Δ</sub>	M <sub>2</sub> /M <sub>N</sub>	M <sub>1</sub> /M <sub>N</sub>	I <sub>Δ</sub> /I <sub>N</sub>	J
80 L194 HMT	0.47	1380	2.0 / 1.15	1.55/0.86	0.74	77.7	79.0	78.5	3.21	2.5	2.6	5.0	0.0019	
90 SH94 HMT	0.67	1400	2.48/1.52	1.82/0.92	0.84	78.0	81.8	81.8	4.68	2.6	2.7	5.6	0.0024	
100 SH94 HMT	1.0	1420	3.48/2.0	2.0 / 1.16	0.86	81.0	83.8	83.8	6.7	2.4	2.6	6.2	0.006	
100 L194 HMT	1.5	1430	4.64/2.66	2.68/1.55	0.81	84.2	89.0	89.0	8.64	3.0	3.5	7.3	0.0075	

1800 1/min  
60 Hz

265/460 V / 460 VΔ  
4 - polig

Type	S1	P <sub>N</sub> [kW]	I <sub>N</sub> [A]	I <sub>Δ</sub> [A]	cos φ	η	1200 P <sub>N</sub> [h]	340 P <sub>N</sub> [h]	440 P <sub>N</sub> [h]	M <sub>Δ</sub>	M <sub>2</sub> /M <sub>N</sub>	M <sub>1</sub> /M <sub>N</sub>	I <sub>Δ</sub> /I <sub>N</sub>	J
80 L194 HMT	0.53	1700	1.9 / 1.1	1.1	0.74	79.0	81.0	80.9	2.97	2.5	2.6	5.4	0.0019	
90 SH94 HMT	0.77	1700	2.4 / 1.36	1.38	0.84	80.8	83.1	82.9	4.33	2.4	2.6	6.0	0.0024	

## DIMENSIONED DRAWINGS OF MOTORS

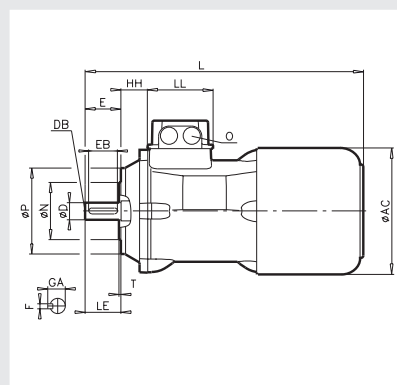

# Standard HM/HMT unventilated



			1500 1/min 50 Hz							230/400 V / 400/690 V 4 - polig			IE3			
			S1													
Type			P <sub>N</sub> [kW]	n <sub>N</sub> [1/min]	I <sub>N</sub>		cos φ	η			M <sub>N</sub> [Nm]	M <sub>A</sub> /M <sub>N</sub>	M <sub>K</sub> /M <sub>N</sub>	I <sub>A</sub> /I <sub>N</sub>	J [kgm <sup>2</sup> ]	kg
					230/400 V [A]	400/690 V [A]		1/2xP <sub>N</sub> [%]	3/4xP <sub>N</sub> [%]	4/4xP <sub>N</sub> [%]						
71	SP/4	HM	0,12	1420	0,66/0,38	0,38/0,22	0,66	60,1	66,8	69,2	0,81	3,22	3,17	4,80	0,00072	5,27
71	MP/4	HM	0,18	1400	0,95/0,55	0,55/0,32	0,70	63,5	68,9	70,0	1,22	3,04	2,98	4,70	0,00086	5,96
71	LP/4	HM	0,25	1400	1,15/0,67	0,67/0,38	0,72	70,1	73,6	73,7	1,69	3,04	2,89	4,80	0,0011	6,85
80	LH/4	HM	0,37	1425	1,70/0,98	0,98/0,57	0,70	73,9	78,2	79,3	2,48	3,50	3,50	5,50	0,0019	10,20
90	SH/4	HM	0,55	1435	2,20/1,27	1,27/0,73	0,78	76,2	80,1	81,2	3,66	3,60	4,10	7,20	0,0034	15,10
100	SH/4	HM	0,75	1450	2,86/1,65	1,65/0,95	0,80	76,9	81,0	82,5	4,94	3,50	4,10	7,70	0,0060	21,00
100	LH/4	HM	1,10	1445	4,16/2,40	2,40/1,39	0,78	79,5	83,0	84,1	7,25	3,90	4,30	7,90	0,0075	25,20

			1800 1/min 60 Hz							265/460 V / 460 VΔ			IE3			
			S1													
Type			P <sub>N</sub> [kW]	n <sub>N</sub> [1/min]	I <sub>N</sub>		cos φ	η			M <sub>N</sub> [Nm]	M <sub>A</sub> /M <sub>N</sub>	M <sub>K</sub> /M <sub>N</sub>	I <sub>A</sub> /I <sub>N</sub>	J [kgm <sup>2</sup> ]	kg
					265/460 V [A]	460 VΔ [A]		1/2xP <sub>N</sub> [%]	3/4xP <sub>N</sub> [%]	4/4xP <sub>N</sub> [%]						
71	SP/4	HM	0,12	1730	0,59/0,34	0,34	0,61	59,2	66,4	69,5	0,66	4,00	4,03	5,70	0,00072	5,27
71	MP/4	HM	0,18	1720	0,85/0,49	0,49	0,65	63,3	70,1	72,3	1,00	3,86	3,80	5,60	0,00086	5,96
71	LP/4	HM	0,25	1720	1,03/0,60	0,60	0,69	70,1	74,8	76,2	1,38	3,76	3,70	6,00	0,0011	6,85
80	LH/4	HM	0,37	1735	1,54/0,89	0,89	0,68	69,8	75,6	78,2	2,03	4,20	4,30	6,50	0,0019	10,20
90	SH/4	HM	0,55	1740	1,97/1,14	1,14	0,75	73,7	78,9	81,1	3,01	4,30	4,90	8,20	0,0034	15,10
100	SH/4	HM	0,75	1755	2,55/1,47	1,47	0,78	79,9	83,9	85,5	4,08	4,20	4,90	8,80	0,0060	21,00
100	LH/4	HM	1,10	1755	3,71/2,10	2,10	0,76	81,4	85,1	86,5	6,00	4,60	5,10	9,10	0,0075	25,20

## Type plate



Type SK 80 LH/4 HM TF					
3 ~ Mot.		No. 2009471123-100		12345678	
Th.Cl. 155(F)		IP 66		S1	
50 Hz		230/400 VΔ/Y		60 Hz 265/460 VΔ/Y	
1,7/0,98 A		0,37 kW		1,54/0,89 A 0,37 kW	
COS φ 0,7		1425 min <sup>-1</sup>		COS φ 0,68 1735 min <sup>-1</sup>	
V			V		
A			A		
IE3 = 79,3%			IE3 = 78,2%		
Getriebefabrik NORD GmbH & Co. KG, 22939 Barstede / GERMANY					



			S1													
1500 1/min 50 Hz			230/400 V / 400/690 V 4 - polig													
Type			$P_N$ S1 [kW]	$n_N$ [1/min]	$I_N$ 230/400 V [A]	$I_N$ 400/690 V [A]	$\cos \varphi$	$\eta$			$M_N$ [Nm]	$M_A/M_N$	$M_K/M_N$	$I_A/I_N$	J [kgm <sup>2</sup> ]	$\overset{\text{kg}}{\square}$ [kg]
								1/2xP <sub>N</sub> [%]	3/4xP <sub>N</sub> [%]	4/4xP <sub>N</sub> [%]						
80	L/4	HM	0,47	1420	2,17/1,25	1,25/0,72	<b>0,68</b>	70,9	75,7	77,3	3,15	3,6	3,6	5,4	0,0019	10,2
90	S/4	HM	0,67	1435	2,74/1,58	1,58/0,91	<b>0,74</b>	72,4	77,3	79,1	4,45	3,6	4,2	7,2	0,0034	15,1
100	S/4	HM	1,00	1445	3,80/2,20	2,20/1,27	<b>0,79</b>	75,3	79,5	81,0	6,61	3,3	3,9	7,3	0,006	21,0
100	L/4	HM	1,30	1450	5,00/2,95	2,95/1,67	<b>0,75</b>	75,9	80,4	82,1	8,56	4,1	4,5	7,9	0,0075	25,2

			S1													
1800 1/min 60 Hz			265/460 V / 460 VΔ 4 - polig													
Type			$P_N$ S1 [kW]	$n_N$ [1/min]	$I_N$ 265/460 V [A]	$I_N$ 460 VΔ [A]	$\cos \varphi$	$\eta$			$M_N$ [Nm]	$M_A/M_N$	$M_K/M_N$	$I_A/I_N$	J [kgm <sup>2</sup> ]	$\overset{\text{kg}}{\square}$ [kg]
								1/2xP <sub>N</sub> [%]	3/4xP <sub>N</sub> [%]	4/4xP <sub>N</sub> [%]						
80	L/4	HM	0,53	1720	2,08/1,20	1,2	0,69	75,8	80	81,3	2,94	3,6	3,7	5,9	0,0019	10,2
90	S/4	HM	0,77	1735	2,65/1,53	1,53	0,76	76,8	81,0	82,5	4,23	3,8	4,3	7,6	0,0034	15,1
100	S/4	HM	1,15	1740	3,69/2,13	2,13	0,8	79,0	82,8	84,0	6,3	3,4	4,0	7,6	0,006	21,0
100	L/4	HM	1,45	1750	4,85/2,80	2,8	0,75	77,9	82,2	84,0	7,92	4,3	4,7	8,6	0,0075	25,2

## Type plate

					
Type SK 80 L /4 HM TF					
3 ~ Mot.		No. 2009471123-100		12345678	
Th.Cl. 155(F)	IP 66	S1	IEC 60034 (H)		
50 Hz	230/400 VΔ/Y	60 Hz	265/460 VΔ/Y		
	2,17/1,25 A	0,47 kW	2,08/1,2 A	0,53 kW	
	COS 0,68	1420 min <sup>-1</sup>	COS 0,69	1720 min <sup>-1</sup>	
V			V		
A			A		
Getriebebau NORD GmbH & Co. KG, 22939 Bargteheide / GERMANY <a href="http://www.nord.com">www.nord.com</a>					

## HM ventilated

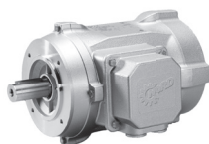

1500 1/min 50 Hz				230/400 V & 400/690 V 4 - polig									IE2			
				S1												
Type	P <sub>N</sub> [kW]	n <sub>N</sub> [1/min]	I <sub>N</sub>		cos φ	η			M <sub>N</sub> [Nm]	M <sub>A</sub> /M <sub>N</sub>	M <sub>K</sub> /M <sub>N</sub>	I <sub>A</sub> /I <sub>N</sub>	J [kgm <sup>2</sup> ]	kg		
			230/400 V [A]	400/690 V [A]		1/2xP <sub>N</sub> [%]	3/4xP <sub>N</sub> [%]	4/4xP <sub>N</sub> [%]								
80 LH/4 HM L/H	0,75	1420	3,23/1,87	1,87/1,08	0,7	80,4	82,0	81,6	5,05	3,15	3,3	5,3	0,0019	10,2		
90 SH/4 HM L/H	1,1	1435	4,40/2,54	2,54/1,47	0,76	81,5	83,8	83,6	7,4	3,35	3,7	6,4	0,0034	15,1		
100 SH/4 HM L/H	1,5	1445	5,56/3,21	3,21/1,85	0,8	84,9	86,3	85,8	10,1	3,05	3,65	7,2	0,006	21,0		
100 LH/4 HM L/H	2,2	1440	8,33/4,81	4,81/2,78	0,8	85,4	86,4	85,8	15,2	3,2	3,7	7,1	0,0075	25,2		

1800 1/min 60 Hz				265/460 V & 460 V D 4 - polig									IE2			
				S1												
Type	P <sub>N</sub> [kW]	n <sub>N</sub> [1/min]	I <sub>N</sub>		cos φ	η			M <sub>N</sub> [Nm]	M <sub>A</sub> /M <sub>N</sub>	M <sub>K</sub> /M <sub>N</sub>	I <sub>A</sub> /I <sub>N</sub>	J [kgm <sup>2</sup> ]	kg		
			265/460 V [A]	460 V [A]		1/2xP <sub>N</sub> [%]	3/4xP <sub>N</sub> [%]	4/4xP <sub>N</sub> [%]								
80 LH/4 HM L/H	0,75	1735	2,89/1,67	1,67	0,67	80,1	83,2	83,8	4,13	3,7	4,0	6,4	0,0019	10,2		
90 SH/4 HM L/H	1,1	1745	3,91/2,26	2,26	0,73	81,5	84,3	85,1	6,1	3,9	4,6	7,8	0,0034	15,1		
100 SH/4 HM L/H	1,5	1755	4,88/2,82	2,82	0,78	83,7	86,4	86,9	8,28	3,4	4,45	8,6	0,006	21,0		
100 LH/4 HM L/H	2,2	1750	7,10/4,10	4,10	0,77	85,4	87,6	87,8	12,5	3,7	4,5	8,7	0,0075	25,2		







## Type plate

Type SK 80 LH/4 HM L/H TF					
3 ~ Mot.		No. 2009471123-100		12345678	
Th.Cl. 155(F)		IP 66		S1	
IEC 60034 (H)					
50 Hz		230/400 V Δ/Y		60 Hz	
265/460 V Δ/Y					
3,23/1,87 A		0,75 kW		2,89/1,67 A	
0,75 kW					
COS φ 0,7		1420 min <sup>-1</sup>		COS φ 0,67	
1735 min <sup>-1</sup>					
V			V		
A			A		
IE2 = 81,6 %			IE2 = 83,8 %		
Getriebefabrik NORD GmbH & Co. KG, 22939 Bargteheide / GERMANY <a href="http://www.nord.com">www.nord.com</a>					

2100 1/min 70 Hz			400 V 4 - polig						IE4			
			S1									
Type			$M_N$ [Nm]	$P_N$ [kW]	$n_N$ [1/min]	$I_N$ 400 V [A]	$\eta$ 4/4x $P_N$ [%]	$M_{max}^*$ [Nm]	kT [Nm/A]	kE [mV/rpm]	J [kgm <sup>2</sup> ]	 [kg]
80	T1/4	HM	3,41	0,75	2100	1,46	91,2	13,5	2,30	154,00	0,0011	7,8
90	T3/4	HM	5	1,1	2100	2,08	93,0	28,3	2,40	156,00	0,0024	11,6
100	T5/4	HM	10	2,2	2100	4,16	91,2	53,5	2,40	165,00	0,0060	20,2

\* kurzzeitig

### Type plate

									
Type SK 90 T3/4 HM TF									
3 ~ Mot.		No.							
Th.Cl. 155(F)		IP66		S1		IEC 60034		(H)	
V $\Delta$ /Y	Hz	kW	HP	A		cos $\phi$	min <sup>-1</sup>	%	IE4
195/338	70	1,1	1,5	3,61/2,08		0,97	2100	92,7	
Ur 400 - 460 V		VPWM		CT SF		1,0		Isf 3,61/2,08 A	
KE 90/156 mV/min		K $\tau$ 1,4/2,4 Nm/A		I $_{max}$ 20,4/11,8		A			
R $_{str}$ 2,45 $\Omega$		L $_d$ 27,5 mH		L $_q$ 61,0 mH					
Getriebefabrik NORD GmbH & Co. KG, 22939 Bargteheide / GERMANY 									

# B14 unventilated + PMSM HM

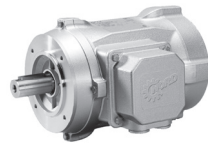

## Standard

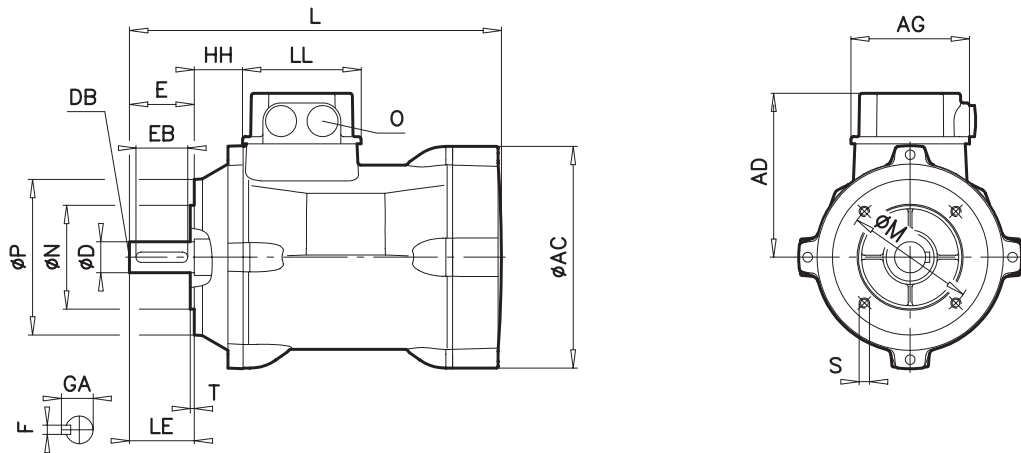

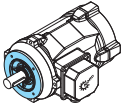
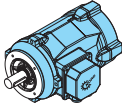
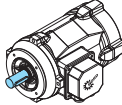
Type	HM / HMT unbelüftet																			
		M	N	P	S	T	AC	AD	AG	HH	L	O	LE	LL	D	DB	E	EB	F	GA
71	SP / MP / LP	85	70	105	M6x12	2,0	136	109	75	32	207	M16x1,5	30	75	14	M5	30	20	5	16
80	L / LH / T1	100	80	120	M6x12	3,0	154	123,5	92	34	243	M20x1,5	40	92	19	M6	40	32	6	21,5
90	S / SH / T3	115	95	140	M8x15	3,0	171	128,5	92	37	288	M20x1,5	50	92	24	M8	50	40	8	27
100	S / L / SH / LH / T5	130	110	160	M8x16	3,5	192	139,5	92	43	324	M20x1,5	60	92	28	M10	60	50	8	31

### IM B14

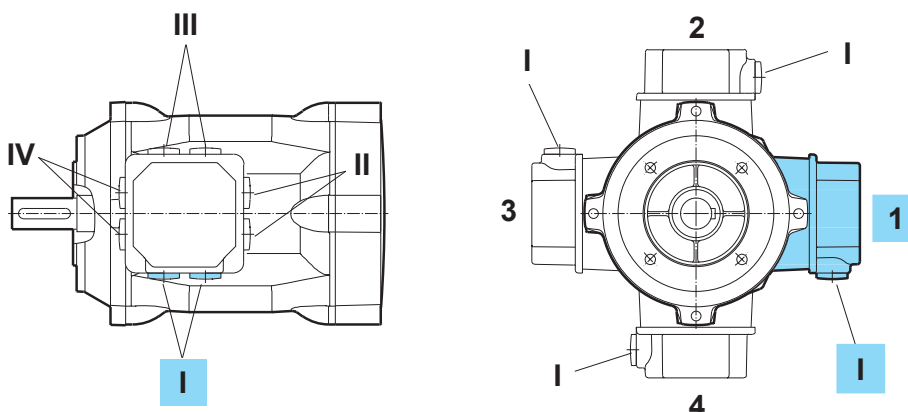
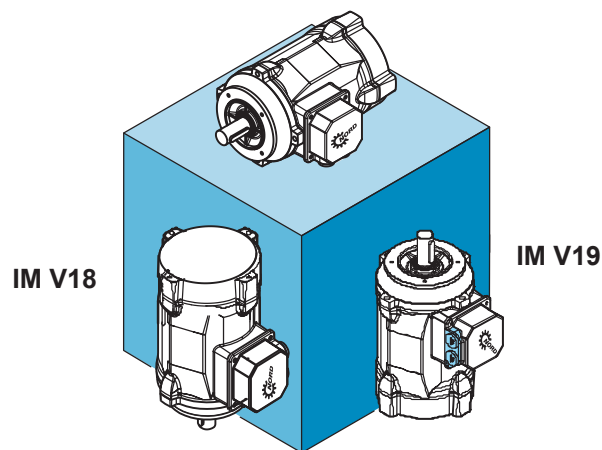



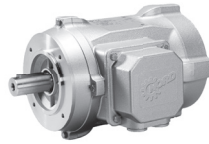

# B14-BRE unventilated

## Standard

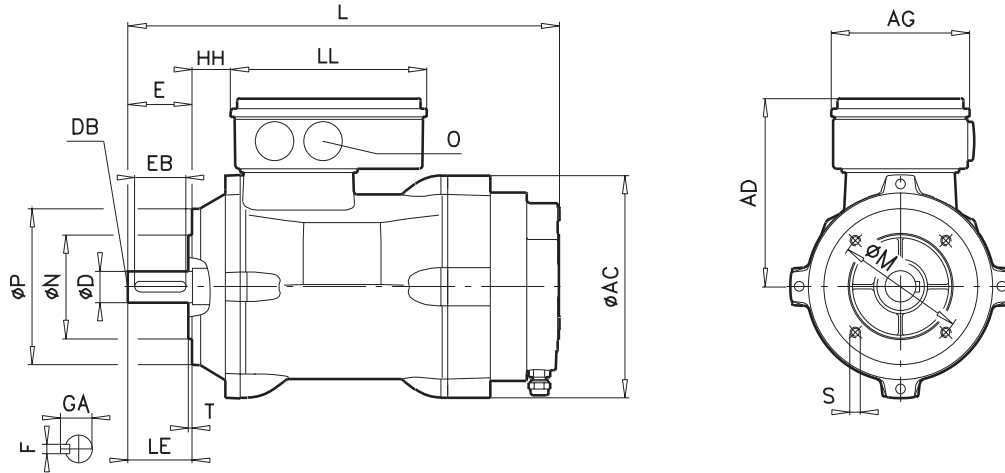

Type		BRE [Nm]																				
HM unbelüftet			M	N	P	S	T	AC	AD	AG	HH	L	O	LE	LL	D	DB	E	EB	F	GA	
80	LH	5 10	100	80	120	M6x12	3,0	154	135	108	26	281 286	M25x1,5	40	153	19	M6	40	32	6	21,5	
90	SH	10 20	115	95	140	M8x15	3,0	171	145	108	30	330 335	M25x1,5	50	153	24	M8	50	40	8	27	
100	SH/LH	10 20	130	110	160	M8x16	3,5	192	167	108	36	367 372	M32x1,5	60	153	28	M10	60	50	8	31	

## Integrated brake

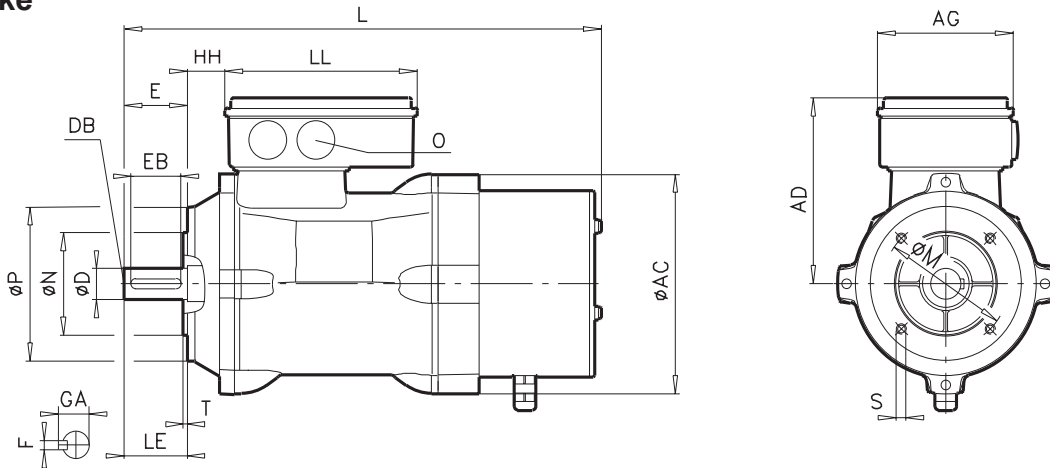

Type		BRE [Nm]																				
HMT unbelüftet			M	N	P	S	T	AC	AD	AG	HH	L	O	LE	LL	D	DB	E	EB	F	GA	
80	LH	5 10	100	80	120	M6x12	3,0	154	135	108	26	333	M25x1,5	40	153	19	M6	40	32	6	21,5	
90	SH	10 20	115	95	140	M8x15	3,0	171	145	108	30	378	M25x1,5	50	153	24	M8	50	40	8	27	
100	SH/LH	10 20	130	110	160	M8x16	3,5	192	167	108	36	415	M32x1,5	60	153	28	M10	60	50	8	31	

# B14 ventilated

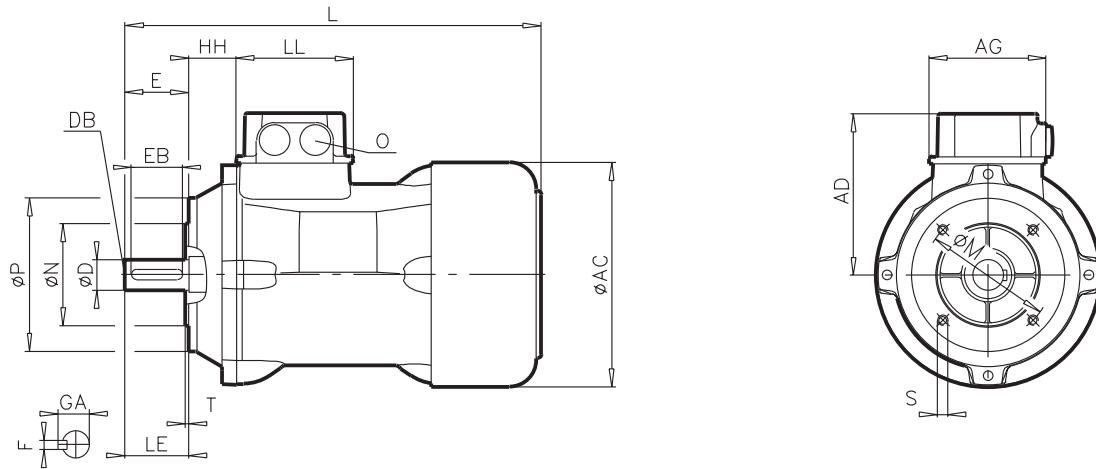

Type	HM	belüftet	L/H
			[mm]

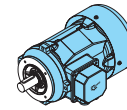
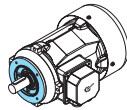

		M	N	P	S	T	AC	AD	AG	HH	L	LE	LL
<b>80</b>	<b>LH</b>	100	80	120	M6 x 12	3,0	156	117	92	26	276	40	114
<b>90</b>	<b>SH</b>	115	95	140	M8 x 15	3,0	176	127	92	30	326	50	114
<b>100</b>	<b>SH/LH</b>	130	110	160	M8 x 16	3,5	194	135	92	36	366	60	114

**IM B14**

**IM V18**

**IM V19**

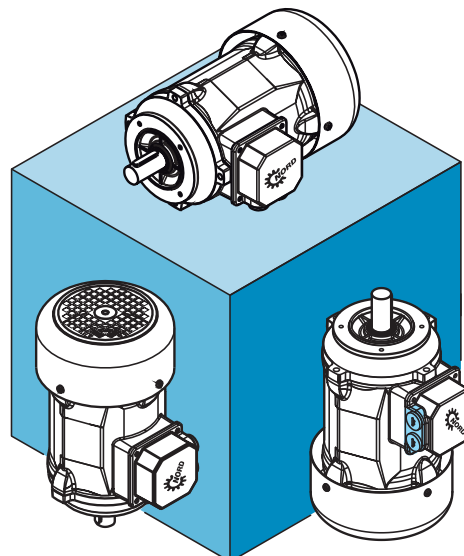

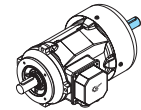
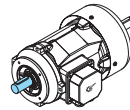
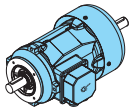
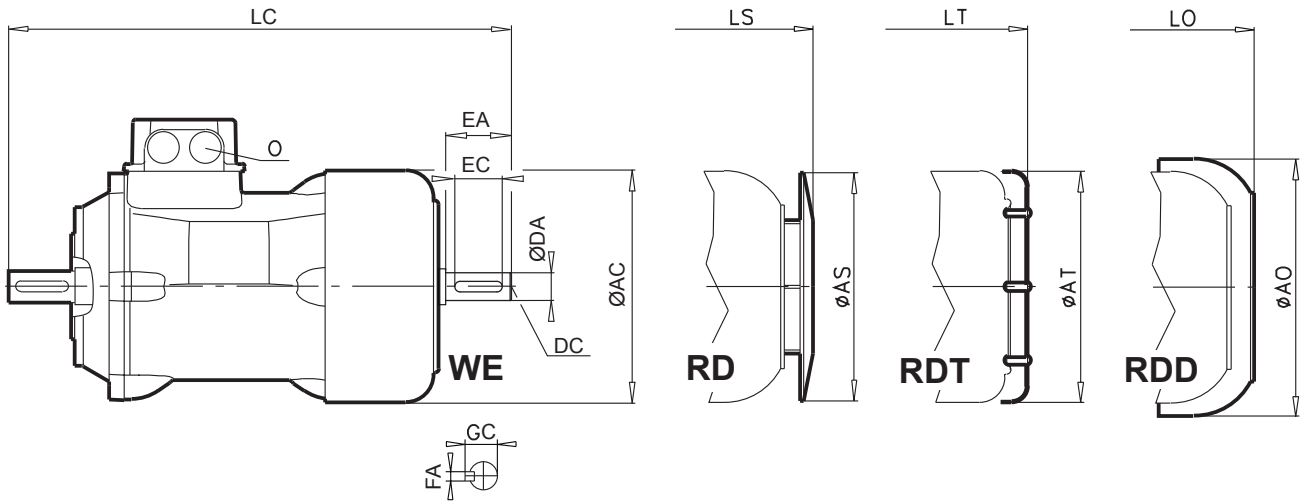

LC	AS	AT	A0	LS	LT	LO	O	D	DB	E	EB	F	GA	DA	DC	EA	EC	FA	GC
309	156	156	176	291	296	302	M20 x 1,5	19	M6	40	32	6	21,5	14	M5	30	20	5	16,0
373	176	176	194	341	345	357	M20 x 1,5	24	M8	50	40	8	27,0	14	M5	30	20	5	16,0
422	194	194	218	381	388	394	M20 x 1,5	28	M10	60	50	8	31,0	24	M8	50	40	8	27,0

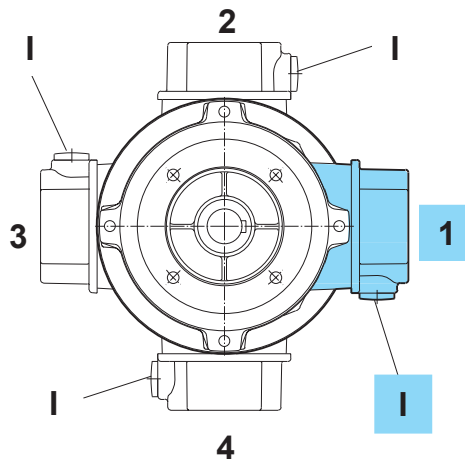
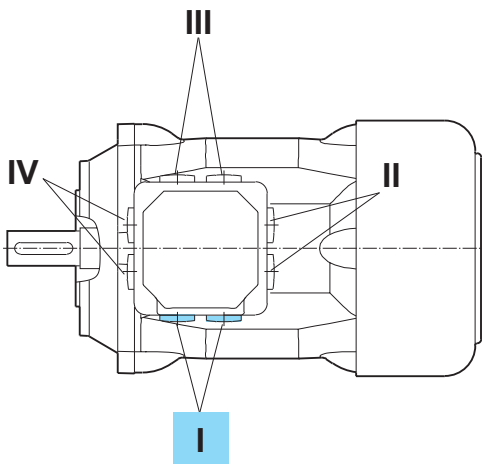

# B14-BRE ventilated

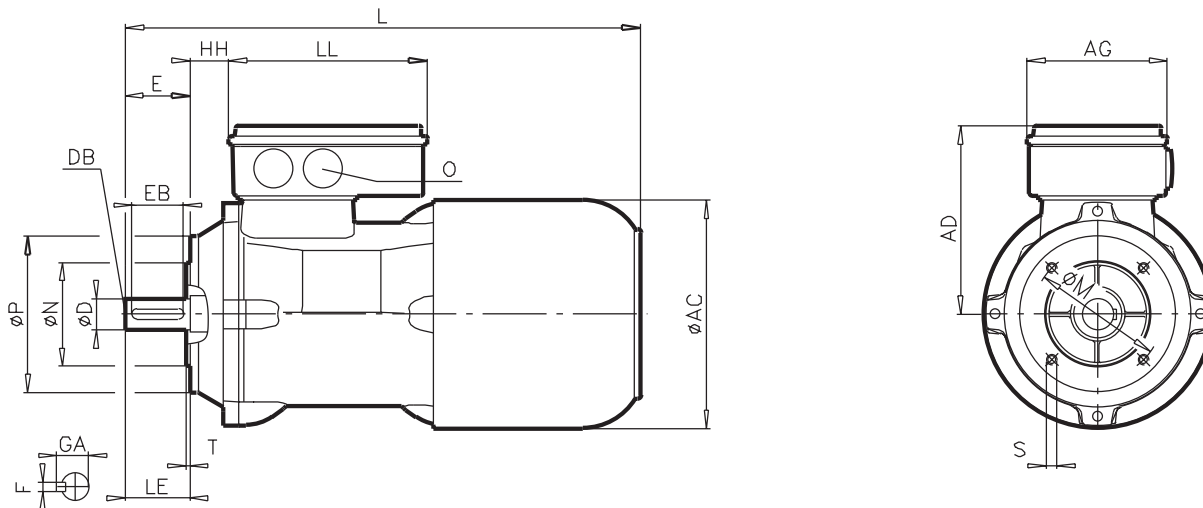
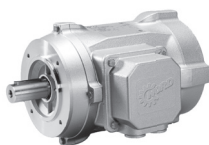

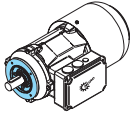
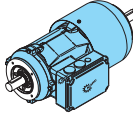
Type		BRE [Nm]											...	
HM belüftet L/H	[mm]		M	N	P	S	T	AC	AD	AG	HH	L	LE	LL
80	LH	5 10	100	80	120	M6 x 12	3,0	156	135	108	26	340	40	153
90	SH	10 20	115	95	140	M8 x 15	3,0	176	145	108	30	401	50	153
100	SH/LH	10 20	130	110	160	M8 x 16	3,5	194	167	108	36	457	60	153

## IM B14

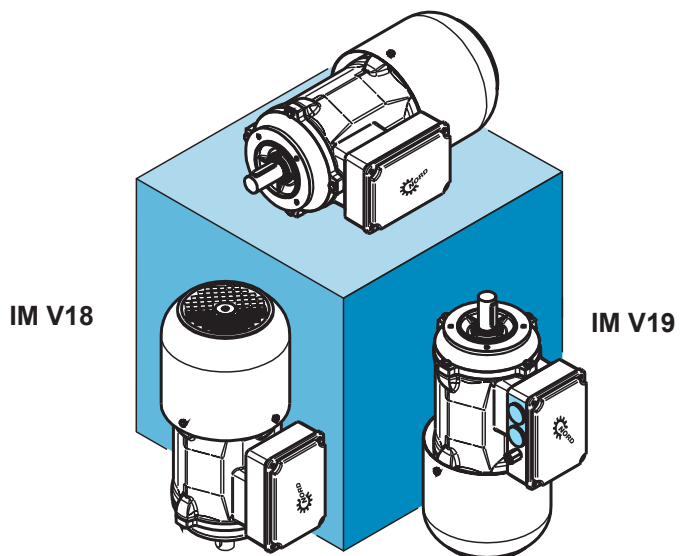



# B14-BRE ventilated

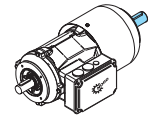
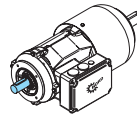
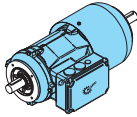
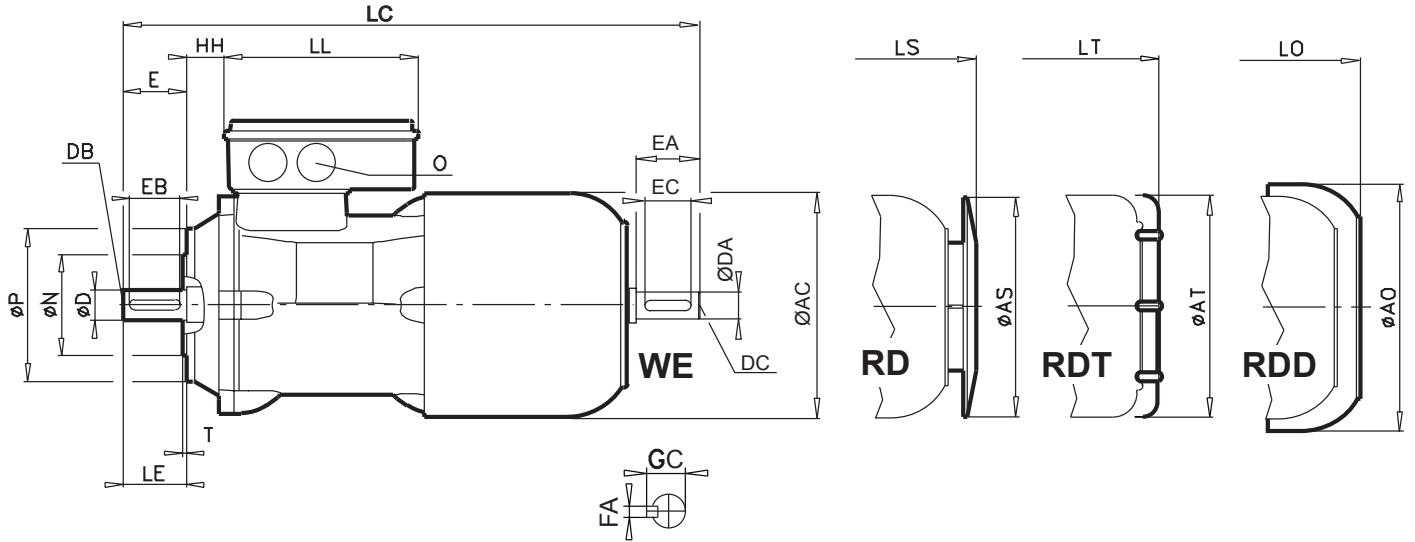

LC	AS	AT	A0	LS	LT	L0	O	D	DB	E	EB	F	GA	DA	DC	EA	EC	FA	GC
374	156	156	176	355	360	366	M25x1,5	19	M6	40	32	6	21,5	14	M5	30	20	5	16,0
439	176	176	194	416	420	431	M25x1,5	24	M8	50	40	8	27,0	14	M5	30	20	5	16,0
517	194	194	218	472	480	485	M32x1,5	28	M10	60	50	8	31,0	24	M8	50	40	8	27,0

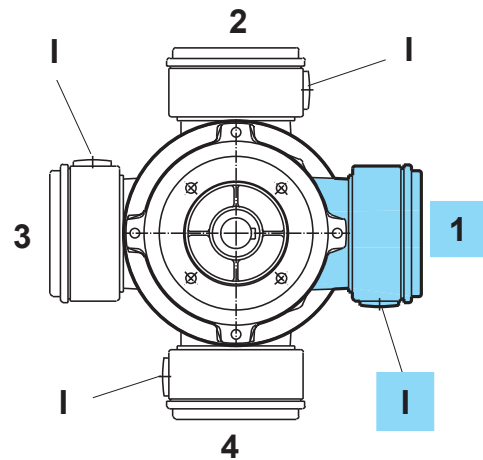
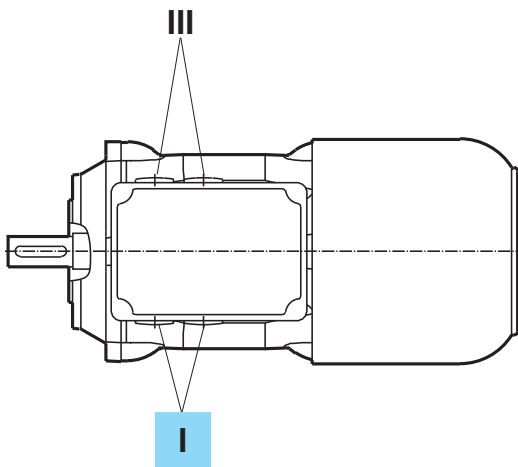

# NORD smooth surface motors

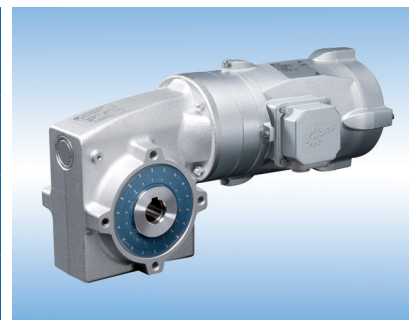

Smooth motor – unventilated  
with SMI worm gear

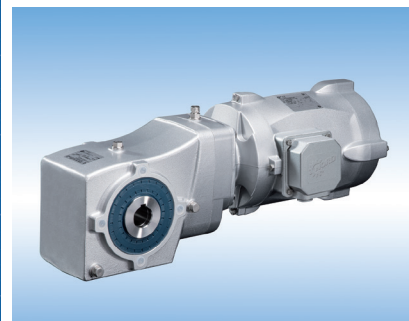

Smooth motor – unventilated  
with 2-stage bevel gear

# An overview of the NORD range

## G1000 Fixed speeds UNICASE housing 50 Hz, 60 Hz

- Helical geared motors
- Parallel geared motors
- Bevel geared motors
- Helical worm geared motors

## G4014 Electronic variable speed drives

- NORDBLOC.1 Helical geared motors
- Helical geared motors
- Parallel geared motors
- Bevel geared motors
- Helical worm geared motors

## G1050 MAXXDRIVE Industrial gear units UNICASE housing 50 / 60 Hz

- Parallel-Axis
- Right-Angle

## G1035 UNIVERSAL Worm gear units

- SI and SMI

## F3018 Frequency inverter SK180E

## F3020 Frequency inverter SK200E

## F3060 NORDAC PRO Frequency inverter SK500P





**NORD DRIVESYSTEMS Group**

**Headquarters and Technology center**  
in Bargteheide close to Hamburg

**Innovative drive solutions**  
for more than 100 branches of industry

**Mechanical products**  
parallell shaft, helical gear, bevel gear and worm gear units

**Electrical products**  
IE2/IE3/IE4 motors

**Electronic products**  
centralised and decentralised frequency inverters,  
motor starters and field distribution systems

**7 state-of-the-art production plants**  
for all drive components

**Subsidiaries and distributors**  
**in 89 countries on 5 continents**  
provide local stocks, assembly, production,  
technical support and customer service

**More than 4.900 employees throughout the world**  
create customer oriented solutions

**[www.nord.com/locator](http://www.nord.com/locator)**

**Headquarters:**

Getriebebau NORD GmbH & Co. KG  
Getriebebau-Nord-Straße 1  
22941 Bargteheide, Germany  
Fon +49 (0) 4532 / 289-0  
Fax +49 (0) 4532 / 289-2253  
[info@nord.com](mailto:info@nord.com), [www.nord.com](http://www.nord.com)

**Member of the NORD DRIVESYSTEMS Group**

